



Variability and Trends in Earth's Radiative Energy Budget from the Inspire-Sat CubeSat constellation and CERES Observations

Introduction

Satellite observations are fundamental for climate monitoring, with **29+ of the 55 Essential Climate Variables (ECVs)** observable only from space.

This is particularly true for the key components of the **Earth Radiative Budget (ERB)** at the **Top of Atmosphere (TOA)**.

Earth's climate system is governed by the balance between:

- **incoming solar radiation (ISR),**
- **reflected shortwave radiation (OSR),**
- **outgoing longwave infrared radiation (OLR).**

A persistent imbalance of less than 1 W m^{-2} is sufficient to drive global warming.

Detecting this weak climate signal — and improving the **link between observations and climate models** — requires:

- **high absolute radiometric accuracy,**
- **full diurnal cycle sampling,**
- **long-term instrumental stability.**

Introduction

The Earth Energy Imbalance (EEI) is the most fundamental indicator of ongoing climate change

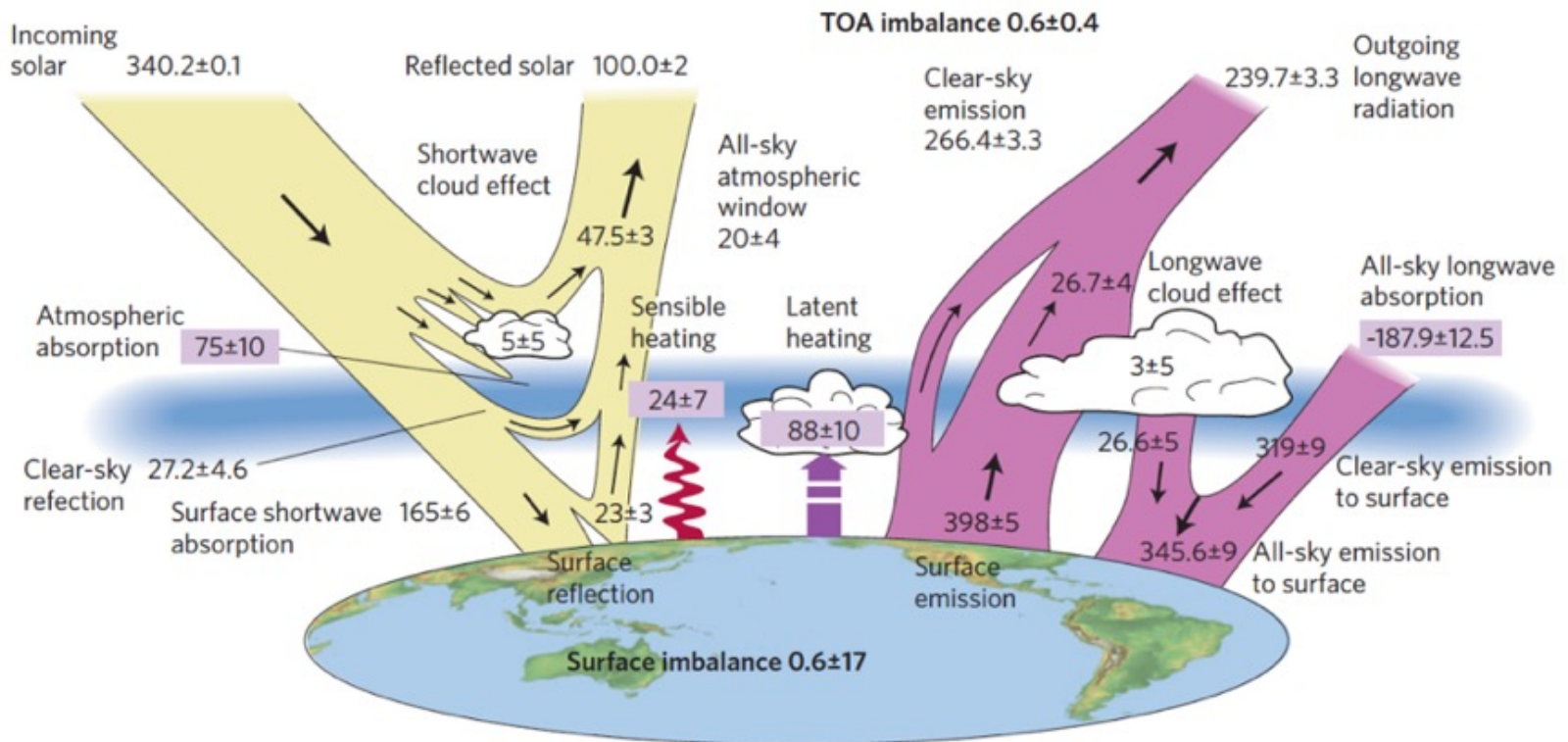

Net radiative flux (NET) \rightarrow Earth Energy Imbalance (EEI) = Incoming solar – [Reflected solar (OSR) + Outgoing longwave radiation (OLR)]

Why the Earth Energy Imbalance Matters

EI links radiative forcing, climate feedbacks, and global temperature response.

Central climate relation: $NET = F - \lambda \Delta T$

- F = radiative forcing
- λ = climate feedback parameter
- ΔT = global surface temperature change
- Even a small persistent imbalance drives long-term climate change.
- More than 90% of the excess energy is stored in the ocean: $NET \sim \frac{dH_{ocean}}{dt}$
- Accurate estimation of the EI therefore requires
 - precise TOA radiative observations,
 - long-term radiometric stability,
 - reliable ocean heat content measurements.

The Earth Energy Imbalance integrates the NET response of the entire climate system.

Challenges in Constraining the ERB

Estimating EEI remains challenging due to uncertainties in:

- **climate feedbacks,**
- **aerosol radiative forcing,**
- **ocean heat uptake.**

Surface temperature alone cannot uniquely constrain the climate response:

$$\text{NET} = F - \lambda \Delta T$$

Deep-ocean mixing strongly influences the transient climate response:

k = ocean heat diffusion coefficient

Aerosols partially offset GHG forcing, introducing uncertainty in historical radiative forcing estimates.

Ocean Heat Content (OHC) provides an independent constraint on the planetary energy imbalance: $\text{NET} \sim \frac{dH_{\text{ocean}}}{dt}$

Constraining the ERB requires combining accurate TOA radiation measurements with robust observations of ocean heat uptake.

Why Satellite Constellations Matter for the ERB

	Short-Term Objectives (Weather & Variability)	Long-Term Objectives (Climate Monitoring)
Primary Goal	Monitor rapid energy variations (ENSO, storms, volcanic eruptions, cloud variability)	Detect and quantify long-term planetary energy imbalance
Key Variables	Regional OSR, OLR, radiative fluxes	Global OSR, OLR, net radiation imbalance
Required Accuracy	~ 1 W m ⁻² sufficient	≤ 1 W m ⁻² mandatory
Instrument Stability	Moderate stability over months–years	≤ 0.1 W m ⁻² per decade required
Temporal Sampling	3-hourly observations to resolve the diurnal cycle	Monthly to decadal continuity essential
Spatial Resolution	10–100 km for clouds and convection	Stable global-scale coverage
Need for Constellations	Multi-orbit observations (GEO + polar) required	Long-term overlap and cross-calibration required
Mission Duration	5–10 years	≥ 30 years for climate continuity (CERES)
Scientific Question	Where and how is energy redistributed today?	Is Earth's energy imbalance evolving over decades?

Satellite constellations are essential to simultaneously resolve short-term radiative variability and long-term climate trends.

Satellites constellation

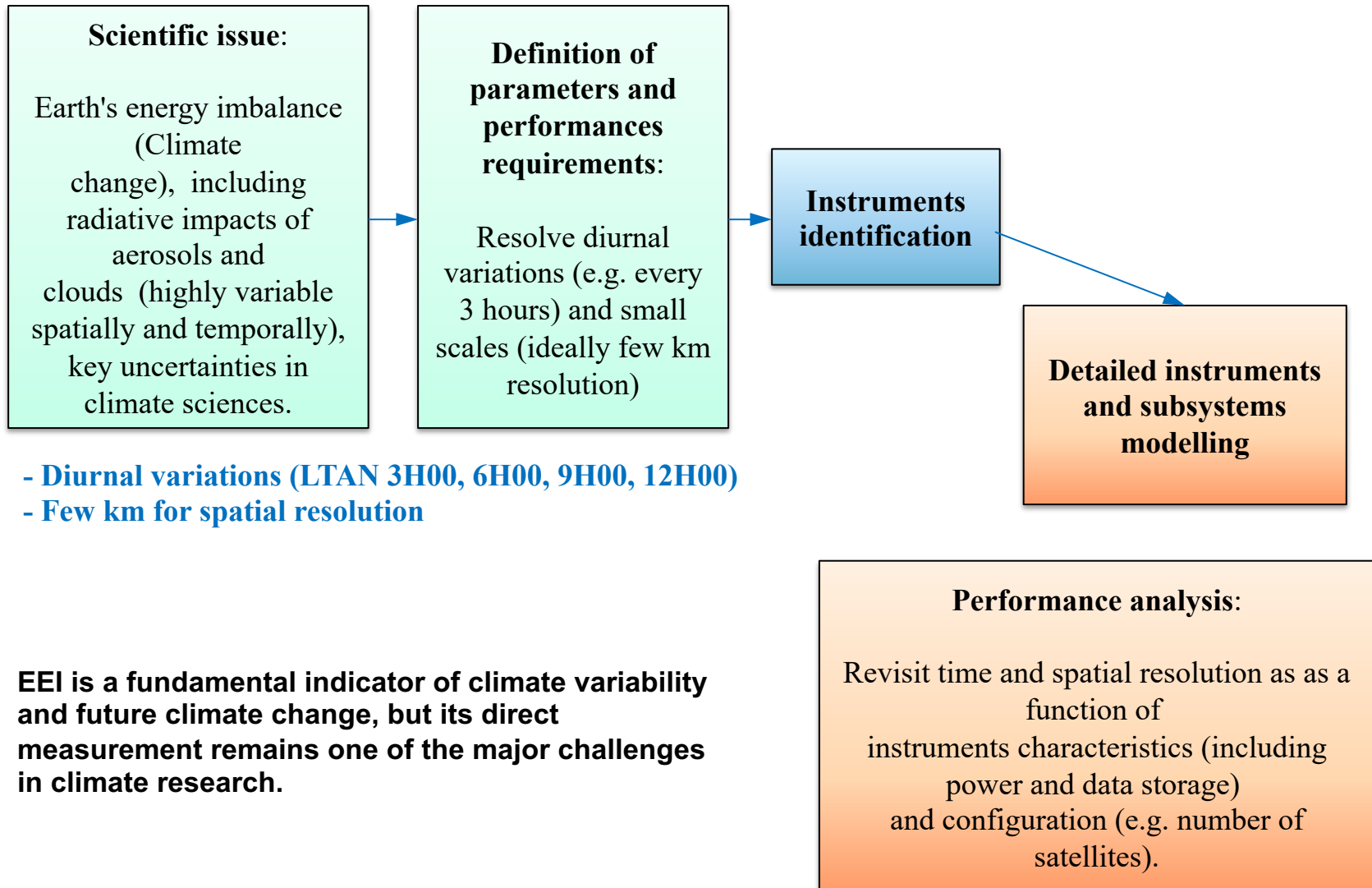
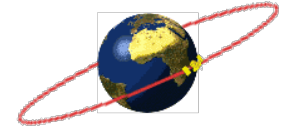

Satellites constellation

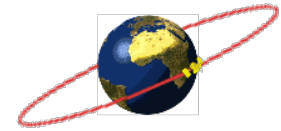

Ground Trace Density - FOV = 130°

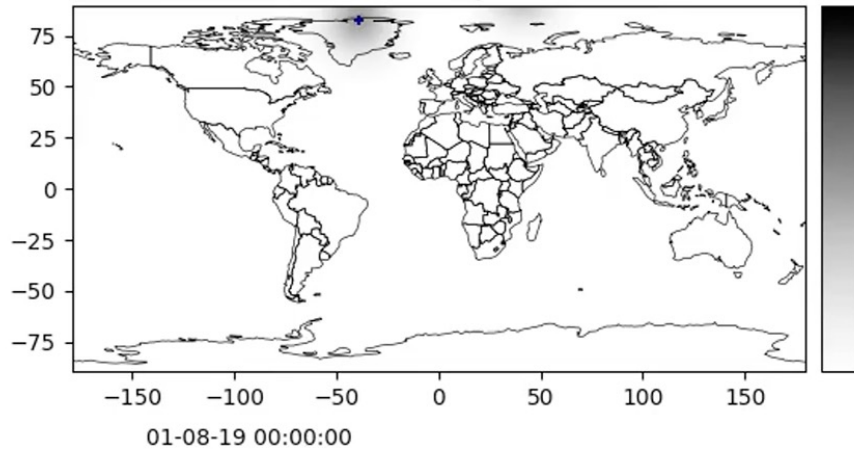

Input Data - Netflux [W/m²]

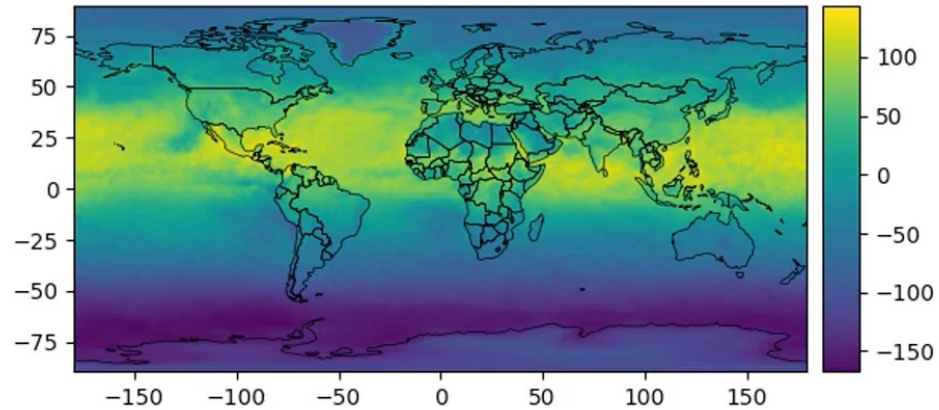

Reconstructed Data - Netflux [W/m²]

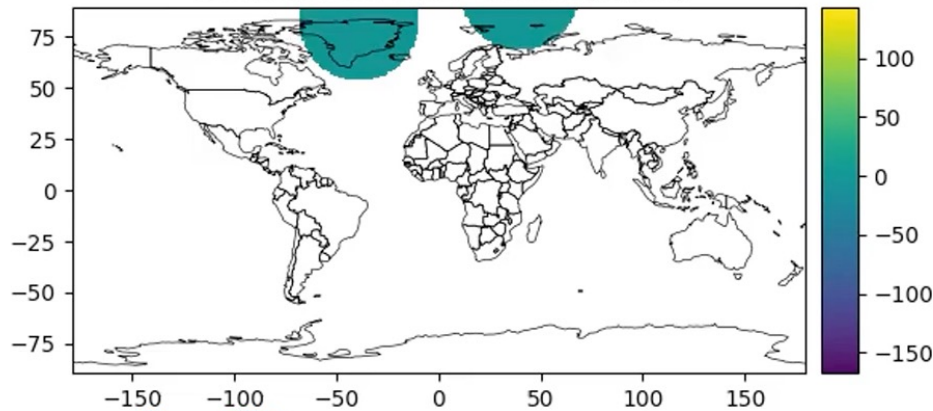

Residual - Netflux [W/m²]

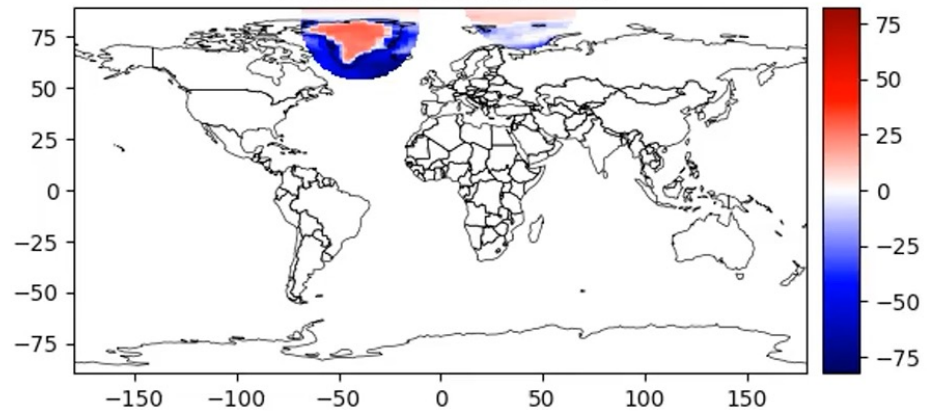

mean (W/m²) = -12.57

std (W/m²) = 28.42

Satellites constellation

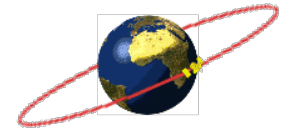

Ground Trace Density - FOV = 2°

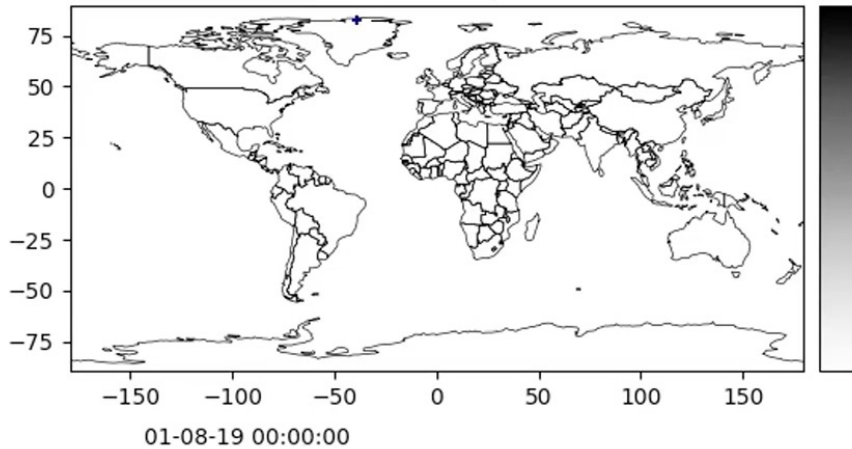

Input Data - Netflux [W/m²]

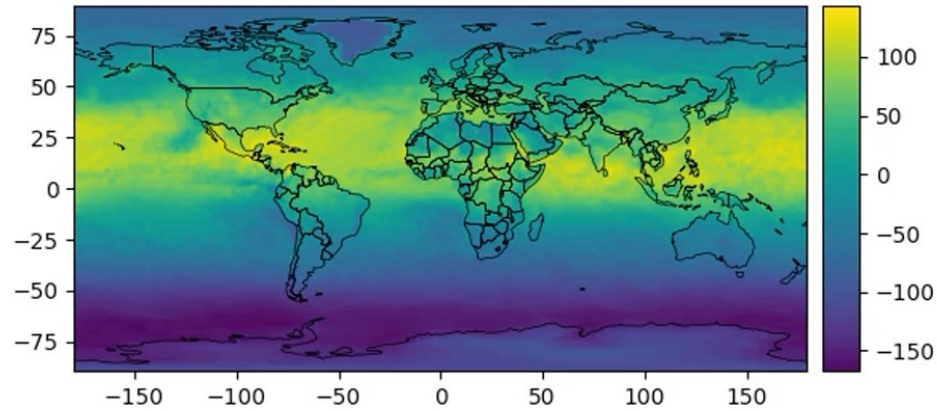

Reconstructed Data - Netflux [W/m²]

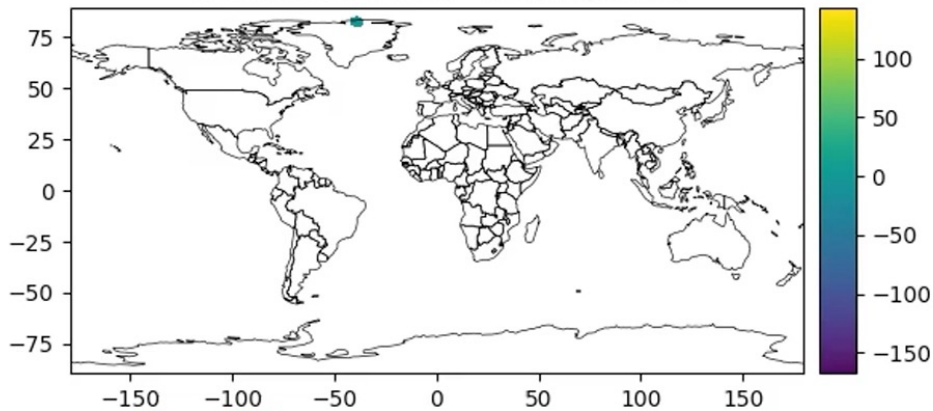

Residual - Netflux [W/m²]

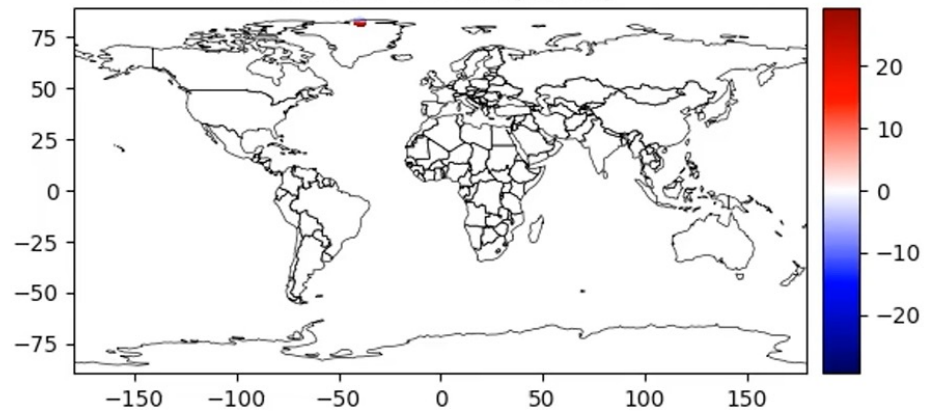

mean (W/m²) = 9.55

std (W/m²) = 15.87

Satellites constellation

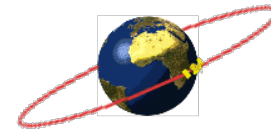

Ground Trace Density - FOV = 130°

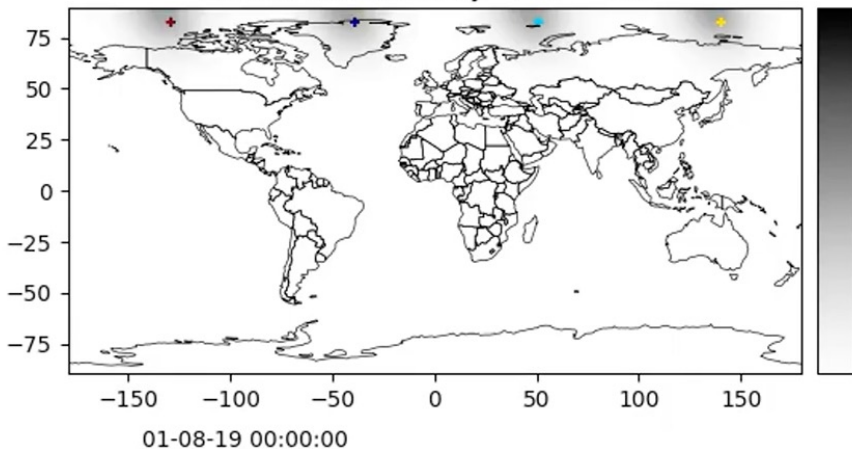

Input Data - Netflux [W/m²]

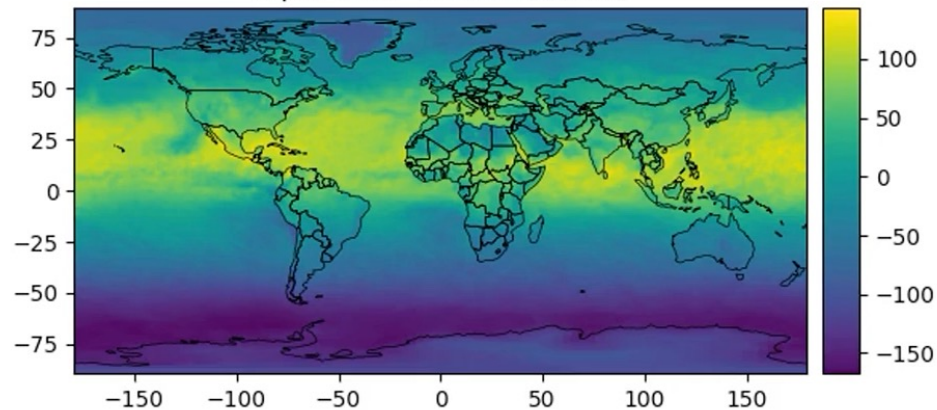

Reconstructed Data - Netflux [W/m²]

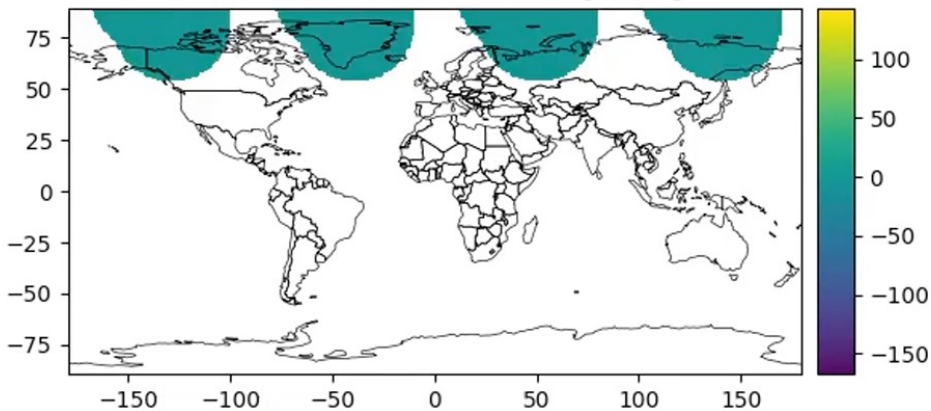

Residual - Netflux [W/m²]

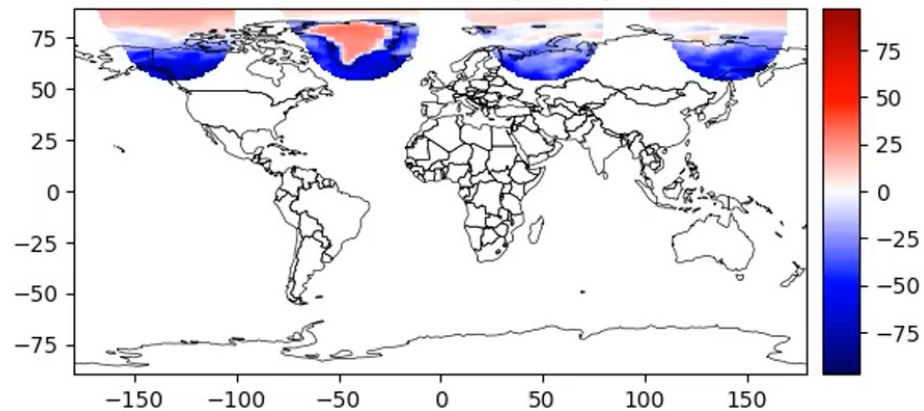

mean (W/m²) = -14.08

std (W/m²) = 28.20

Satellites constellation

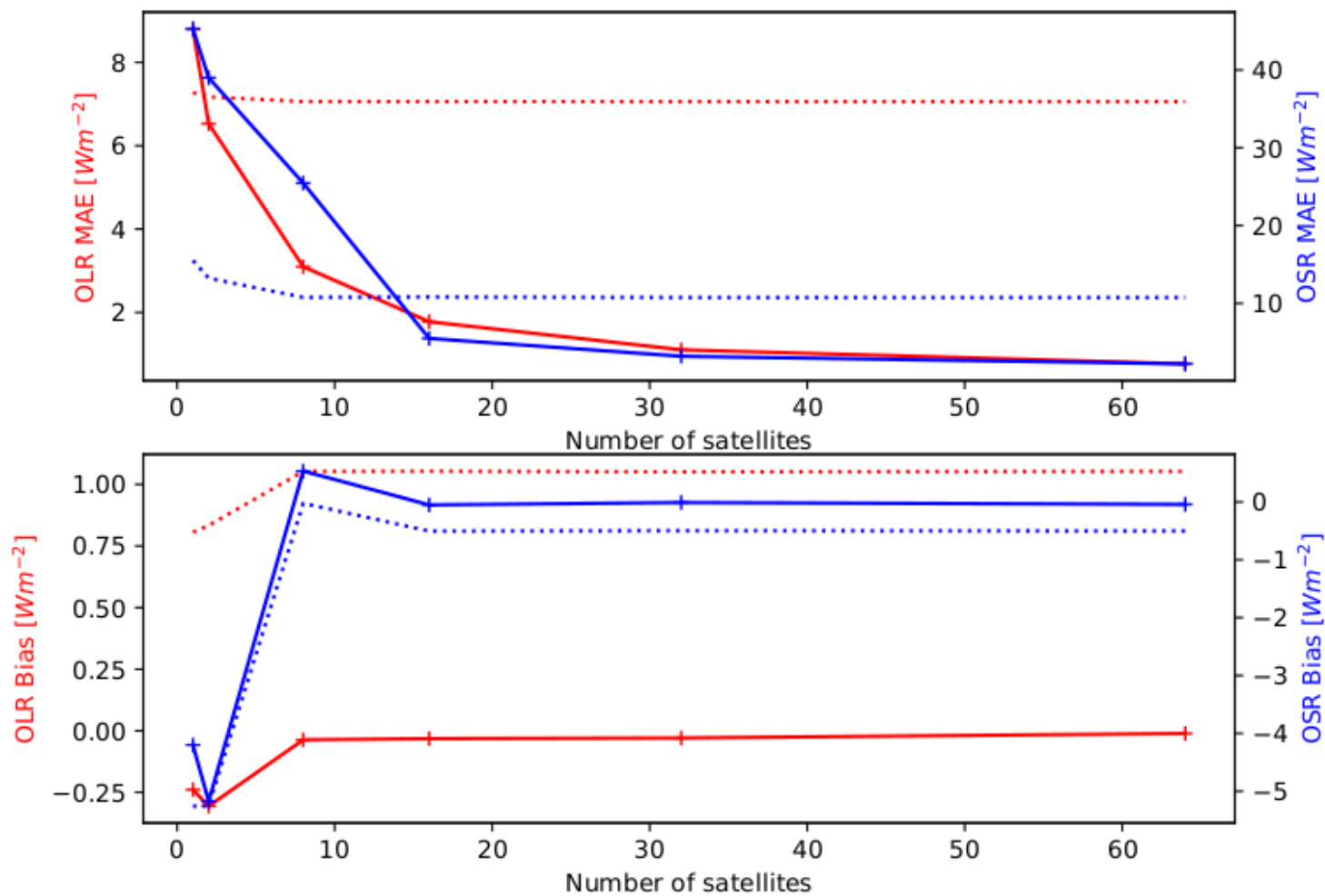
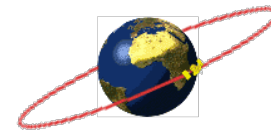

Links with models

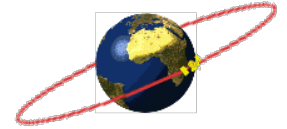

Data Assimilation Systems (ERA 5, ...)

- Constrain atmospheric state variables
- Provide coherent meteorological fields
- Support interpretation of radiative flux variations

Requirement → Temporally complete and scientifically validated observations

Atmospheric and Flux Inversion Models (GEOS-Chem, WRF-Chem, WRF-GC, ...)

- Link observed concentrations and radiative effects
- Quantify aerosol and greenhouse gas forcing
- Study climate feedbacks and EEI drivers

Requirement → High-quality calibrated ERB and atmospheric datasets

CMIP6, CMIP7 models

The Inspire-Sat Constellation

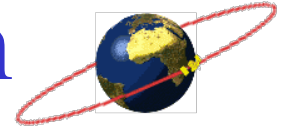

The Uvsq-Sat constellation progressively expands the capability for continuous monitoring of the Earth Radiative Budget.

Constellation Objectives:

- increase temporal sampling of outgoing radiation
 - improve diurnal cycle characterization
 - ensure observational continuity
 - complement reference observations from CERES mission
 - demonstrate scalable constellation-based climate monitoring
-
- **Uvsq-Sat (Jan. 2021)** → First demonstration of compact radiometric ERB observations.
 - **Inspire-Sat (April 2023)** → Extended temporal coverage and complementary observations.
 - **Uvsq-Sat NG (March 2025)** → Next-generation radiometric performance and constellation continuity.

The Inspire-Sat Constellation

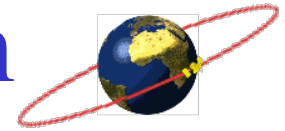

Uvsq-Sat (Inspire-Sat 5)

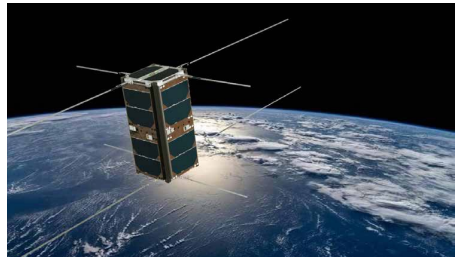
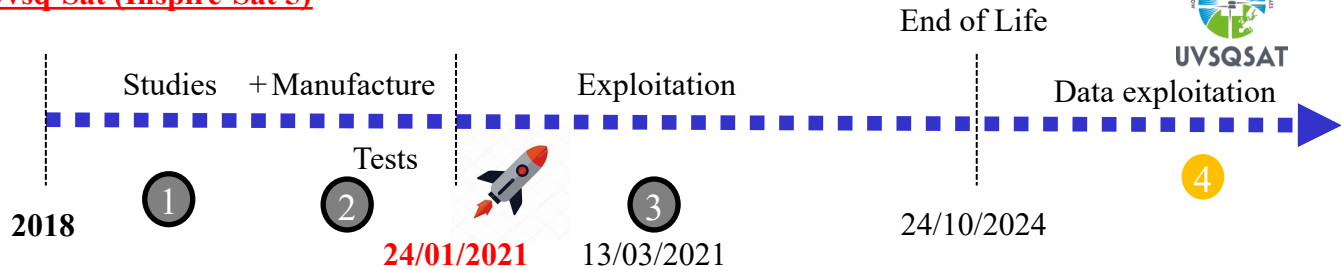

Uvsq-Sat+ (Inspire-Sat 7)

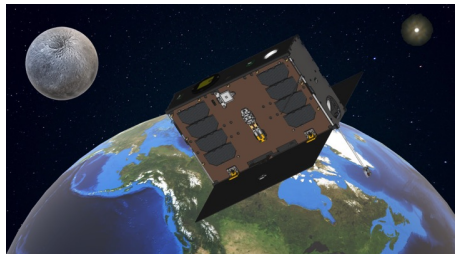
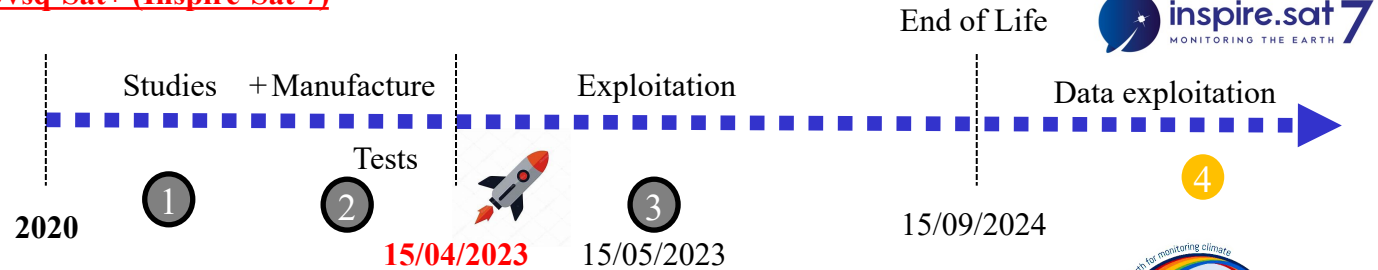

Uvsq-Sat NG (Inspire-Sat X)

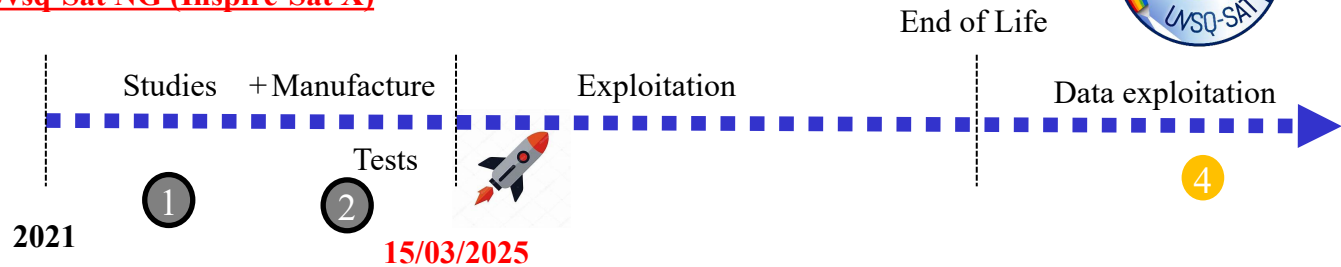

Phases 0/A, B, C, D

Phase E

Phase F

The Inspire-Sat Constellation

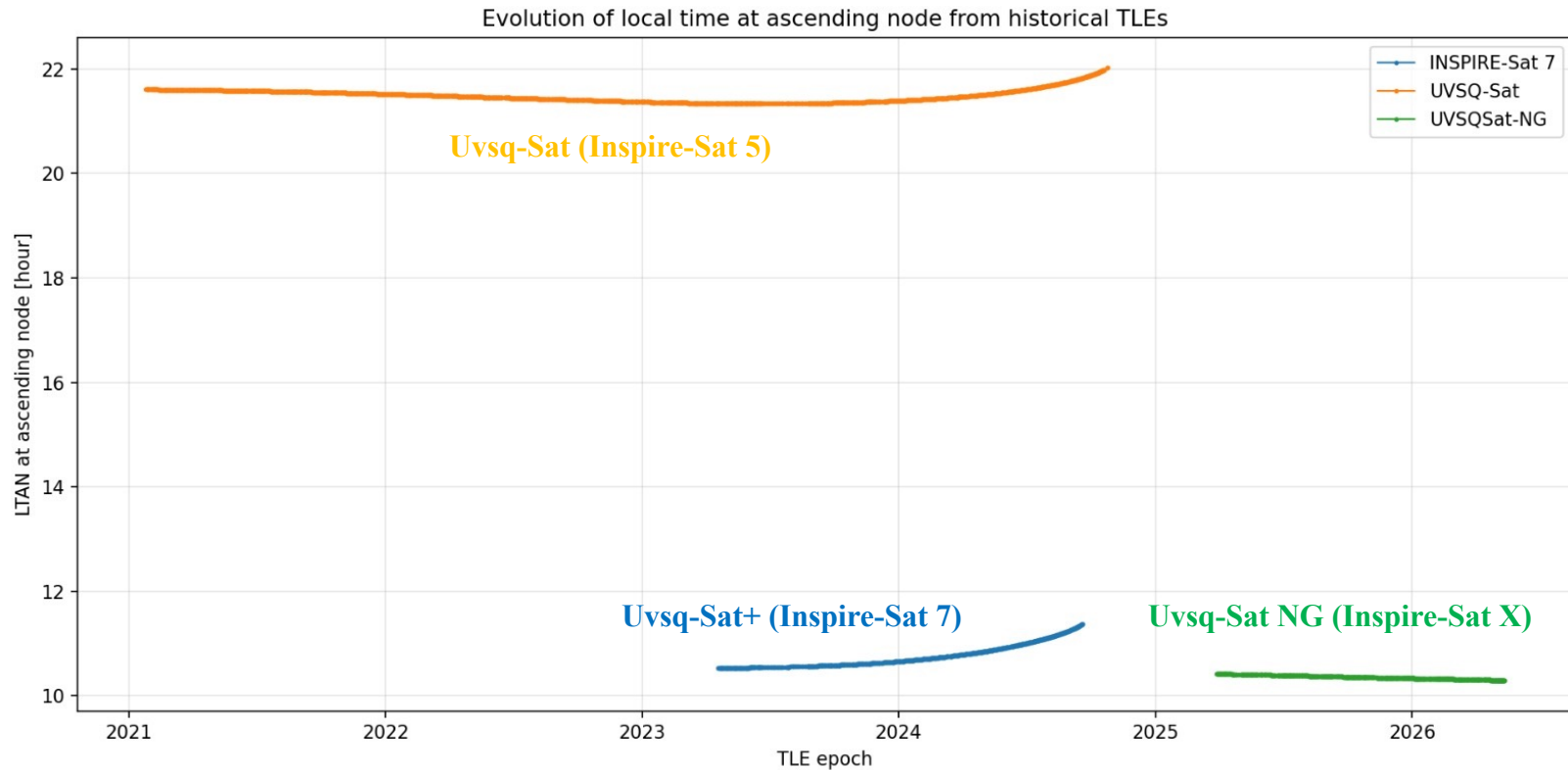
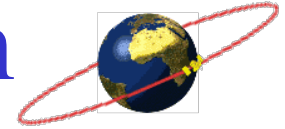

The Inspire-Sat Constellation

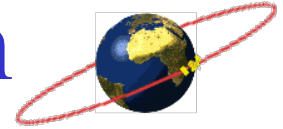

The Uvsq-Sat missions are to demonstrate the potential of compact radiometric constellations for long-term climate monitoring.

Constellations are not intended to replace large climate-reference missions such as CERES, but to complement them.

- complement reference missions,
- improve temporal sampling,
- strengthen climate data record continuity,
- support future operational ERB monitoring systems.

The future of Earth Radiative Budget observation would benefit from synergistic multi-mission and constellation-based architectures.

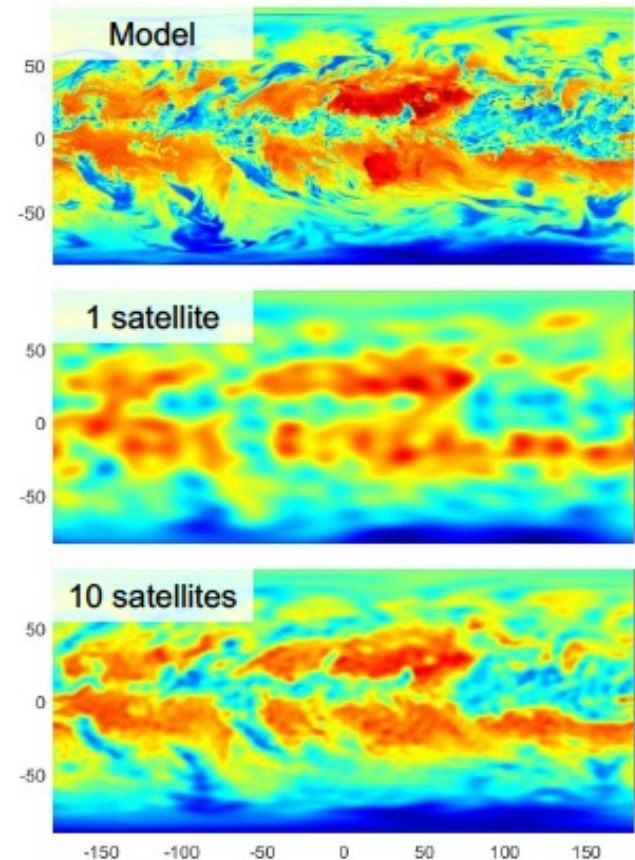

The Inspire-Sat Constellation

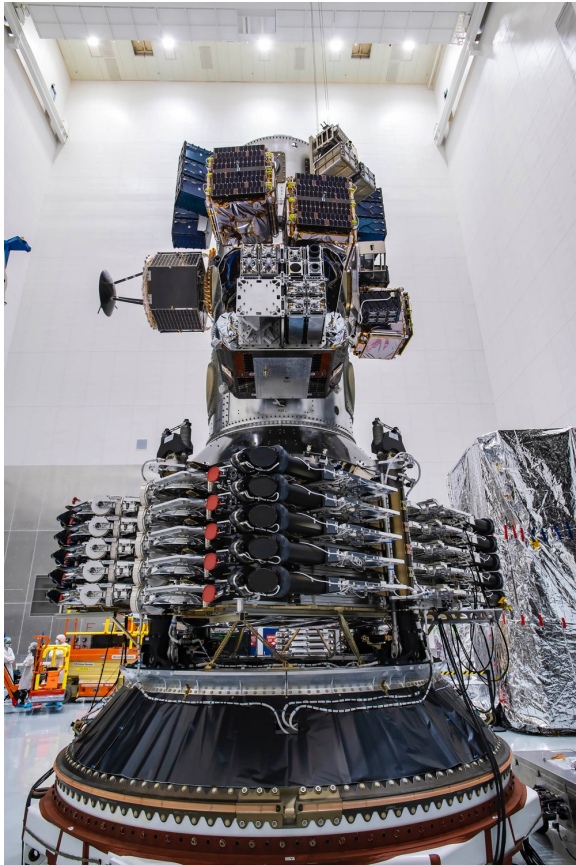
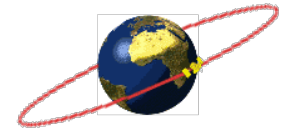

Uvsq-Sat (Inspire-Sat 5)

Transporter 1

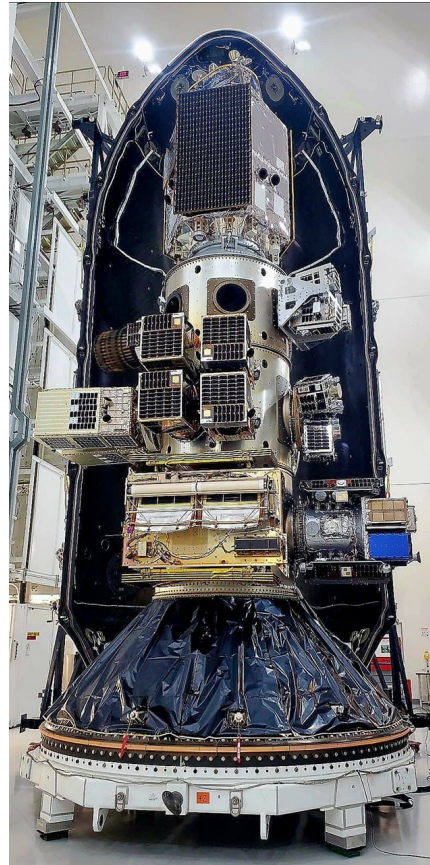

Uvsq-Sat+ (Inspire-Sat 7)

Transporter 7

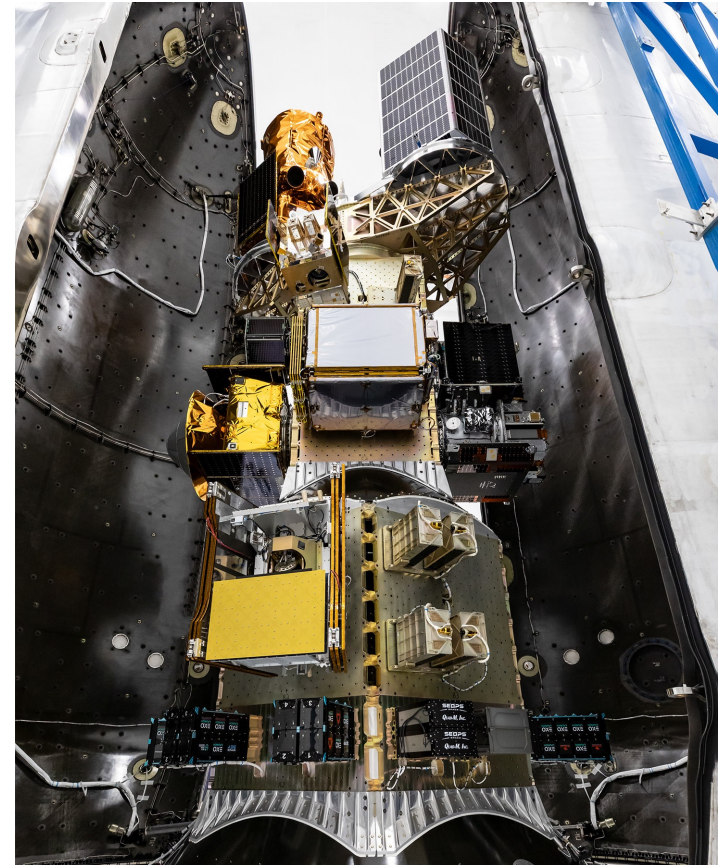

Uvsq-Sat NG (Inspire-Sat X)

Transporter 13

Uvsq-Sat (Inspire-Sat 5)

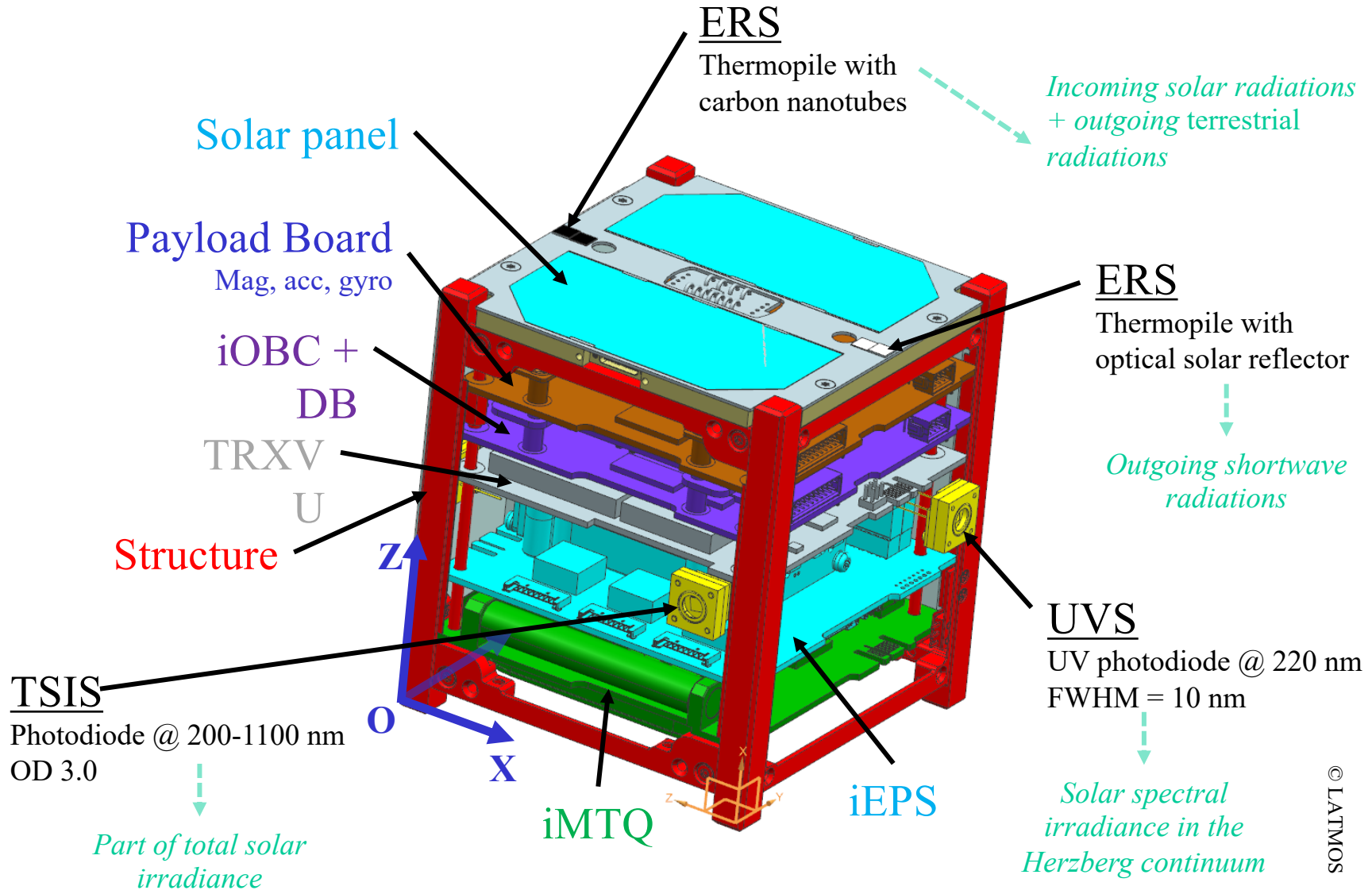

Uvsq-Sat (Inspire-Sat 5)

*Mission launched
in January 2021*

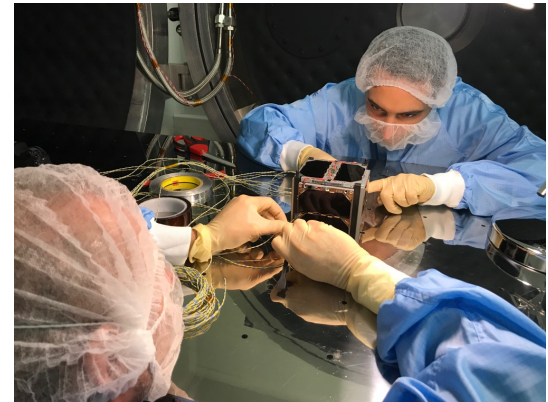
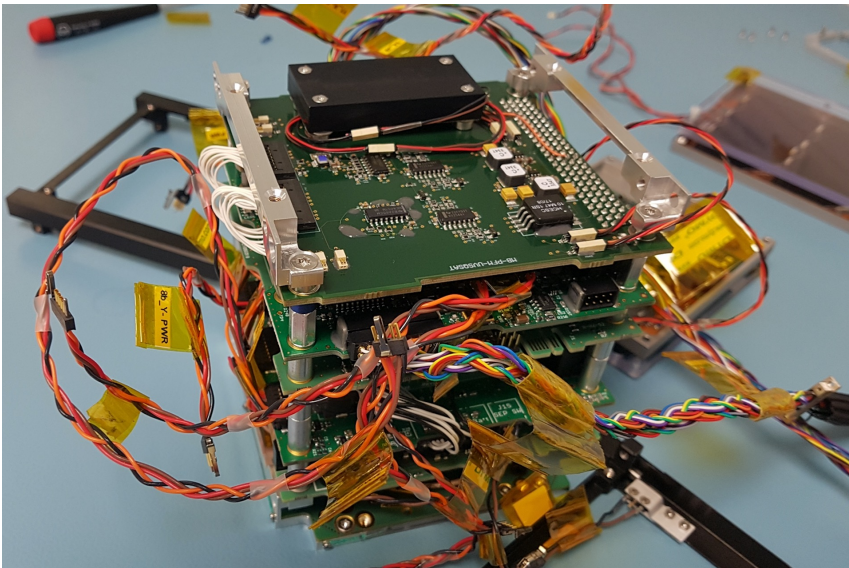
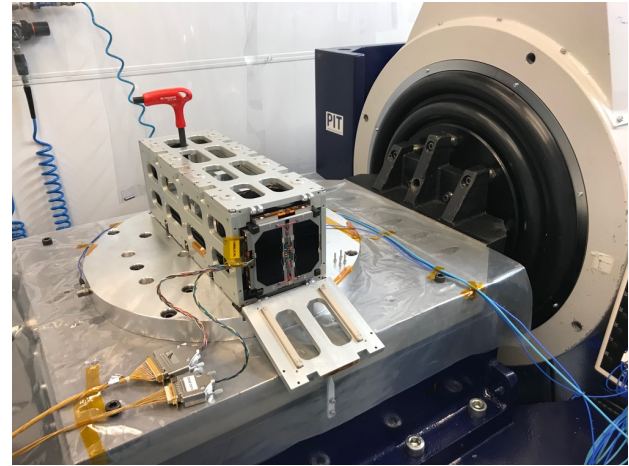
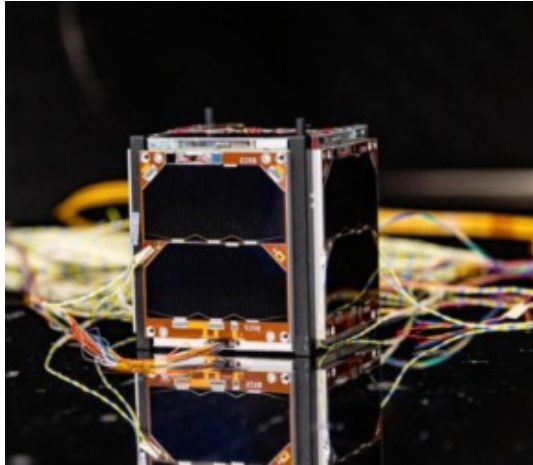

Uvvsq-Sat+ (Inspire-Sat 7)

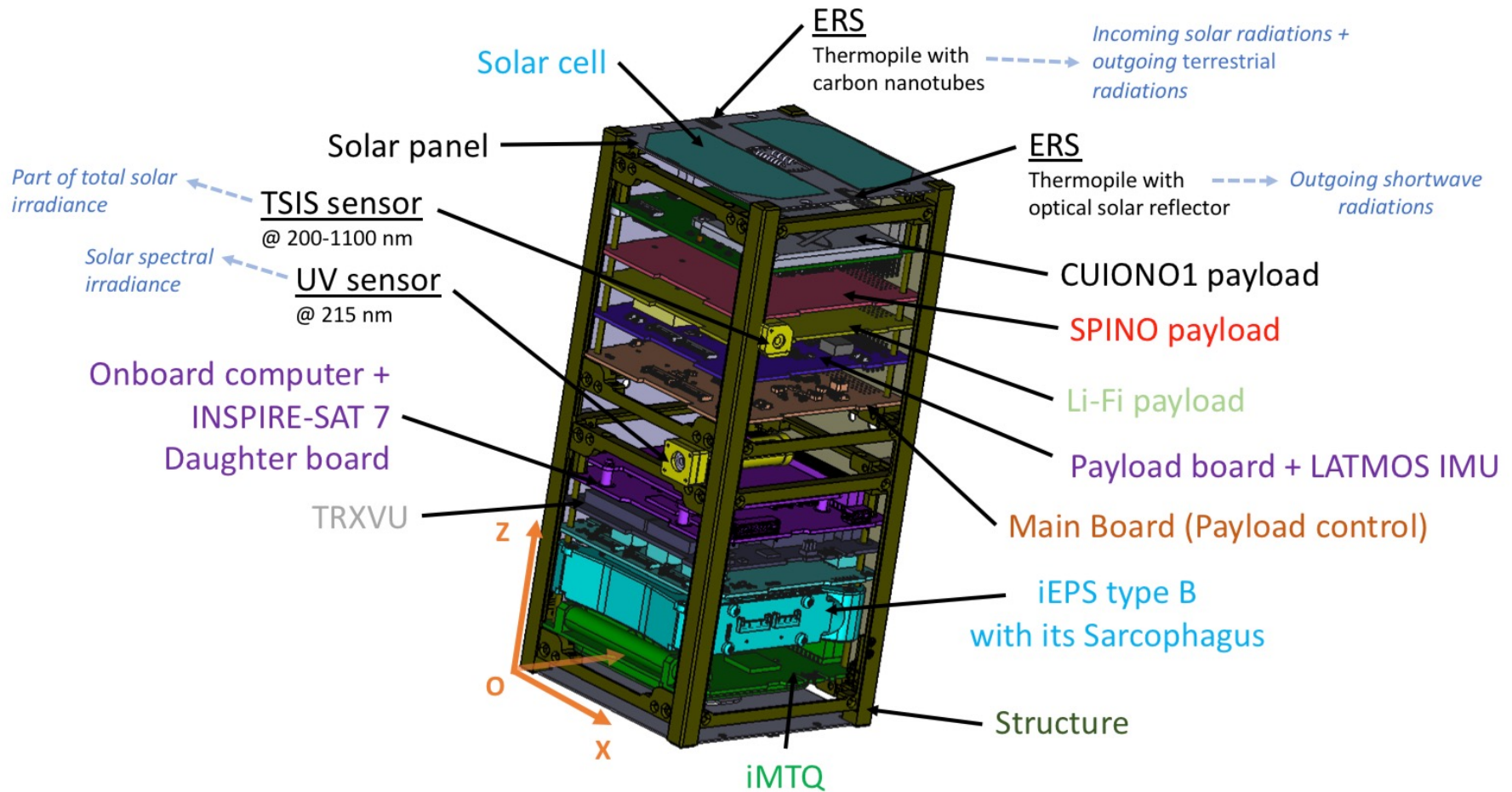

Uvsq-Sat+ (Inspire-Sat 7)

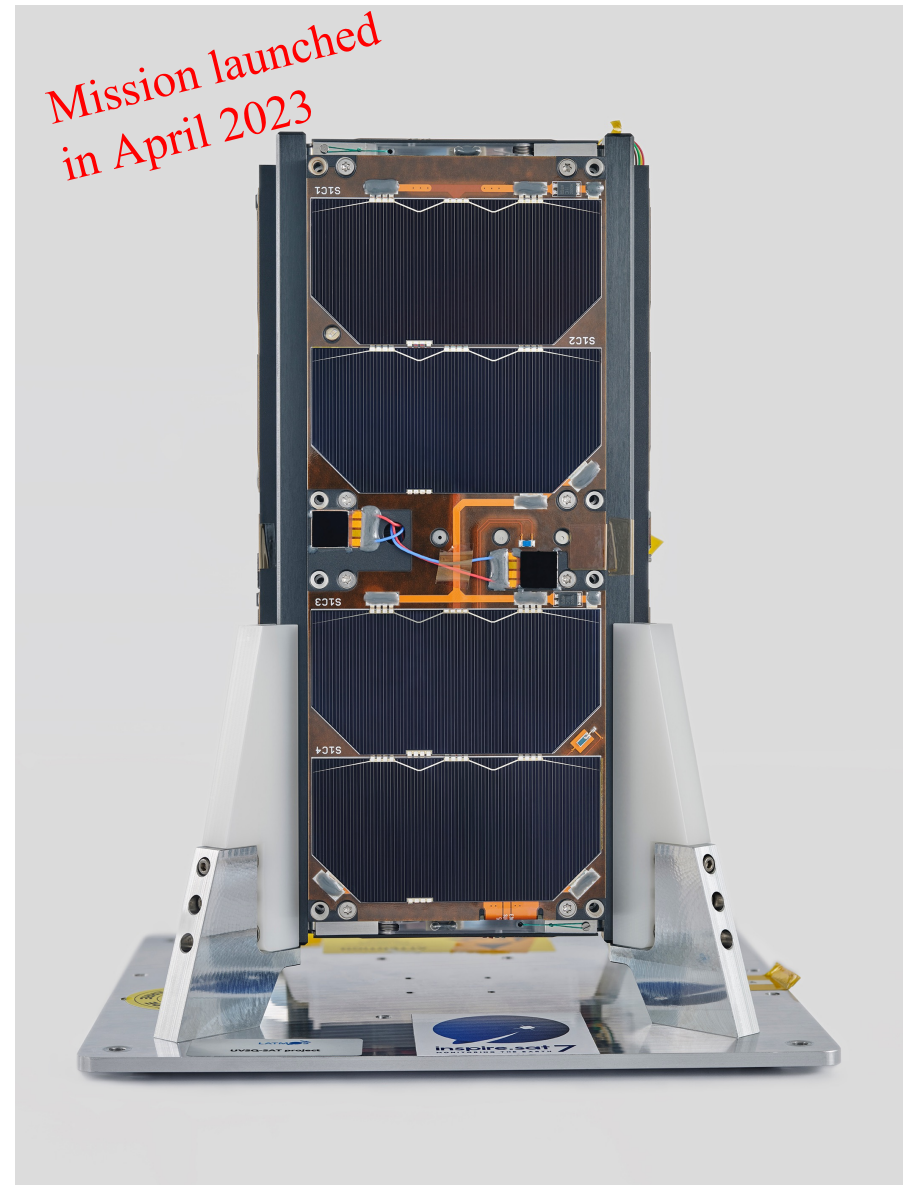
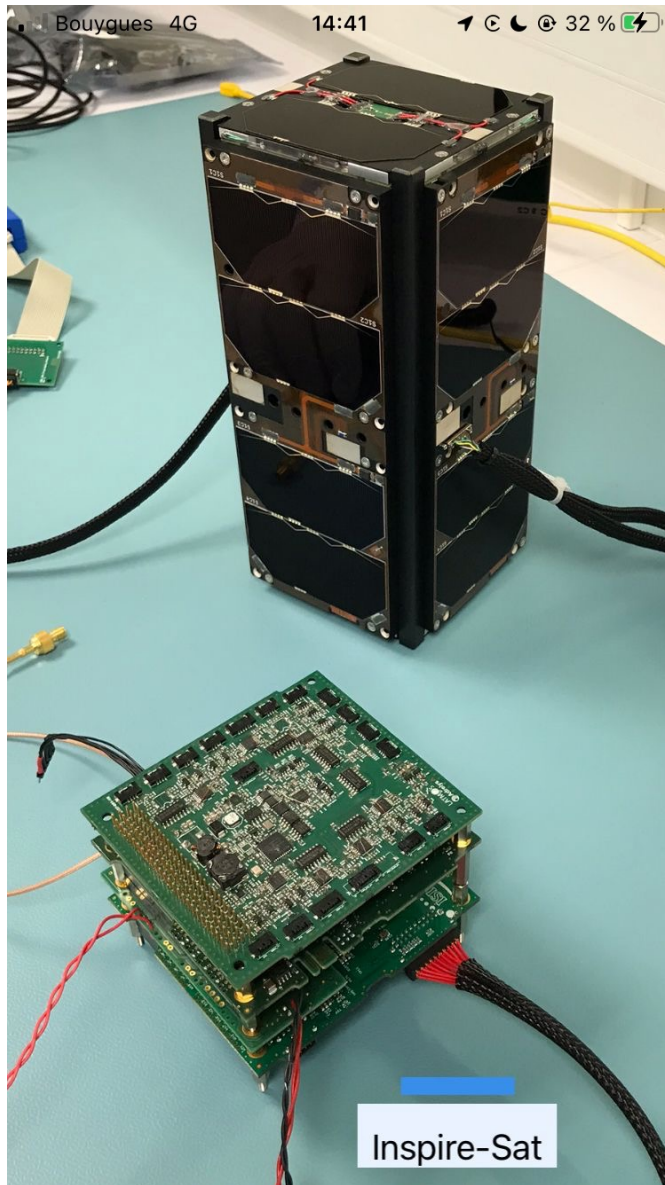

Time-series data from Uvsq-Sat

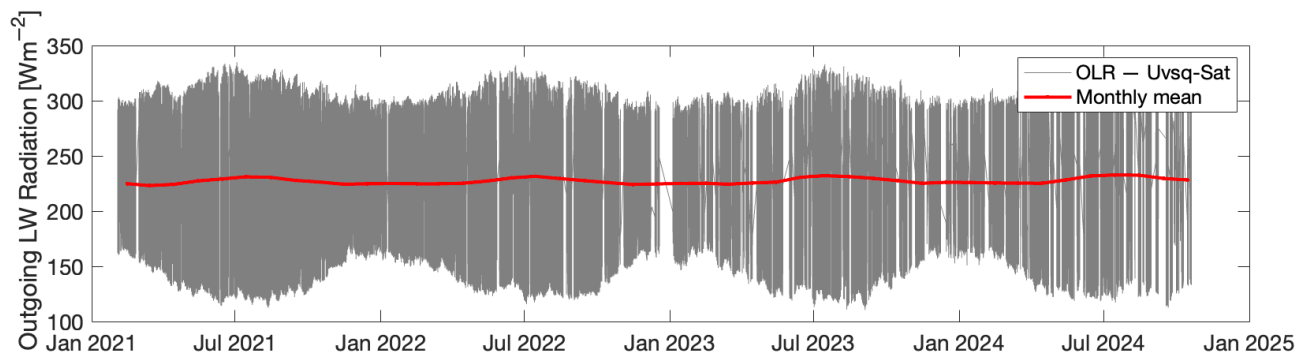
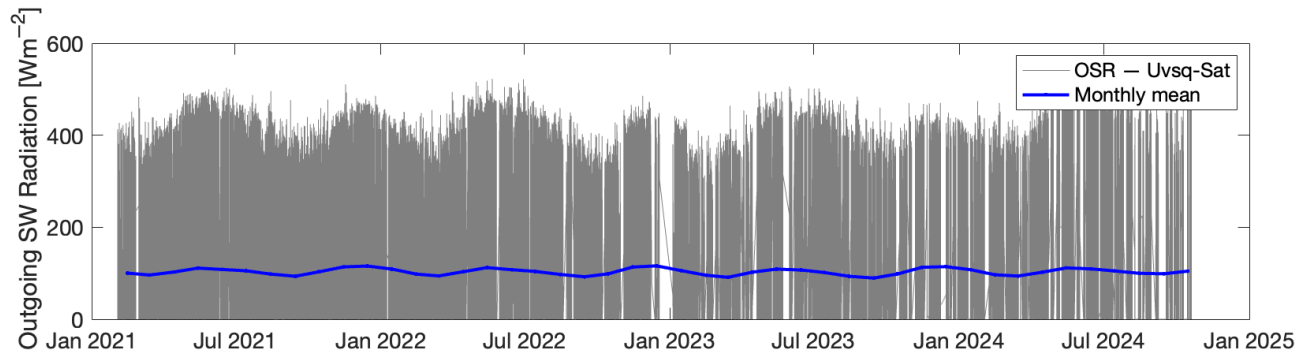
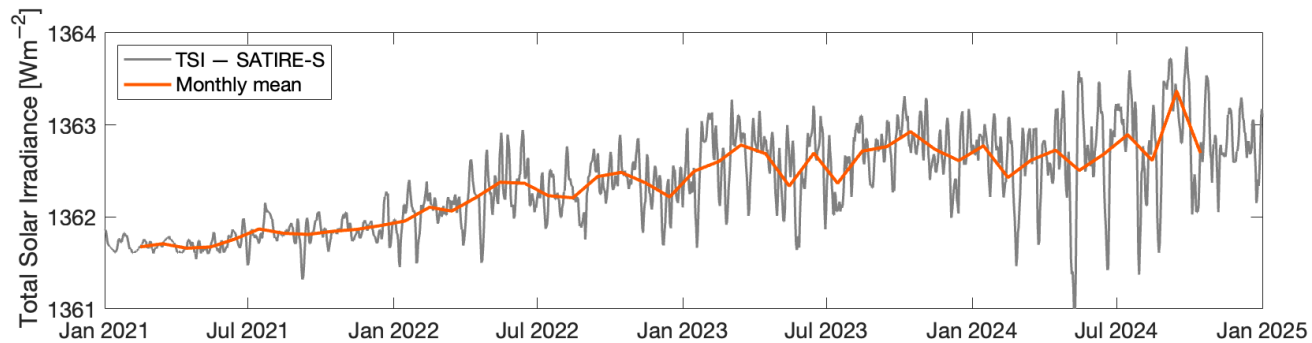

Local ground-point weight

TSIS

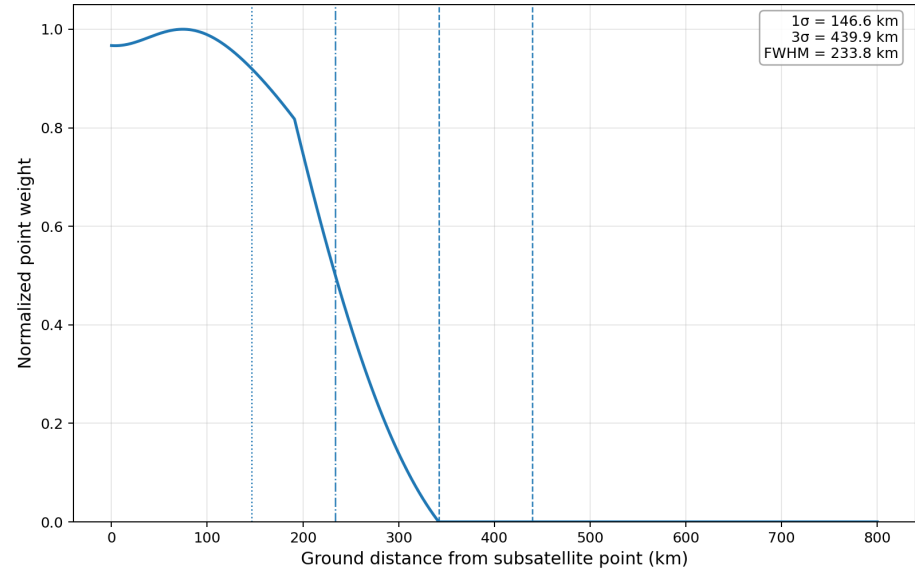
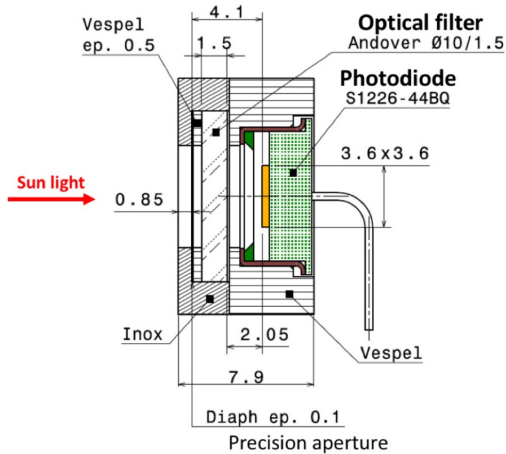

ERS

ERS

Thermopile with carbon nanotubes

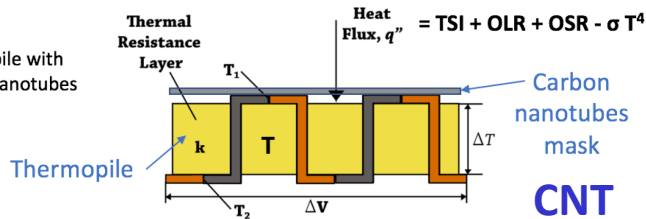

ERS

Thermopile with optical solar reflector

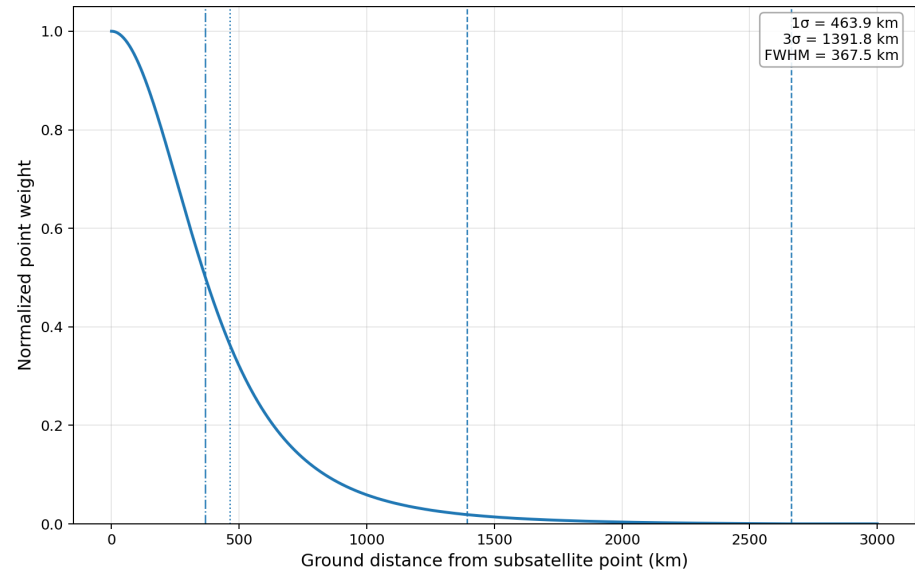
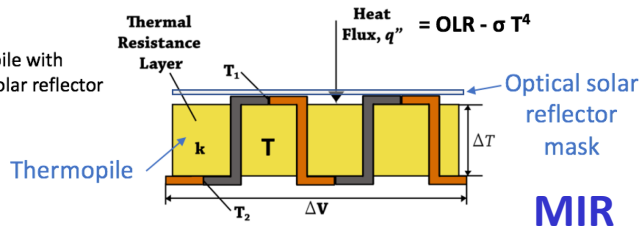

TOA all-sky shortwave (SW) flux from Uvsq-Sat & Inspire-Sat

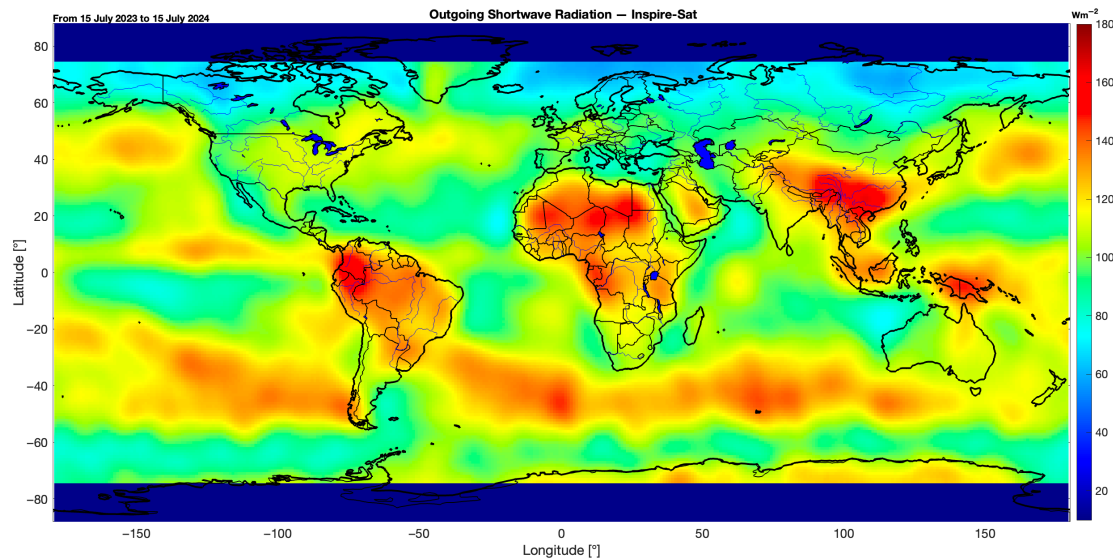
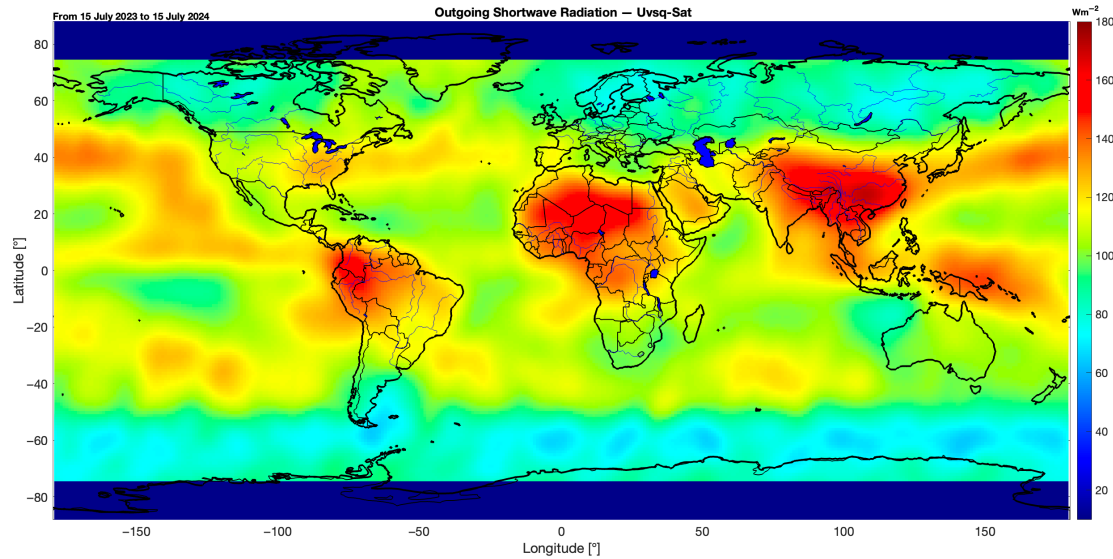

TOA all-sky shortwave (SW) flux from Uvsq-Sat

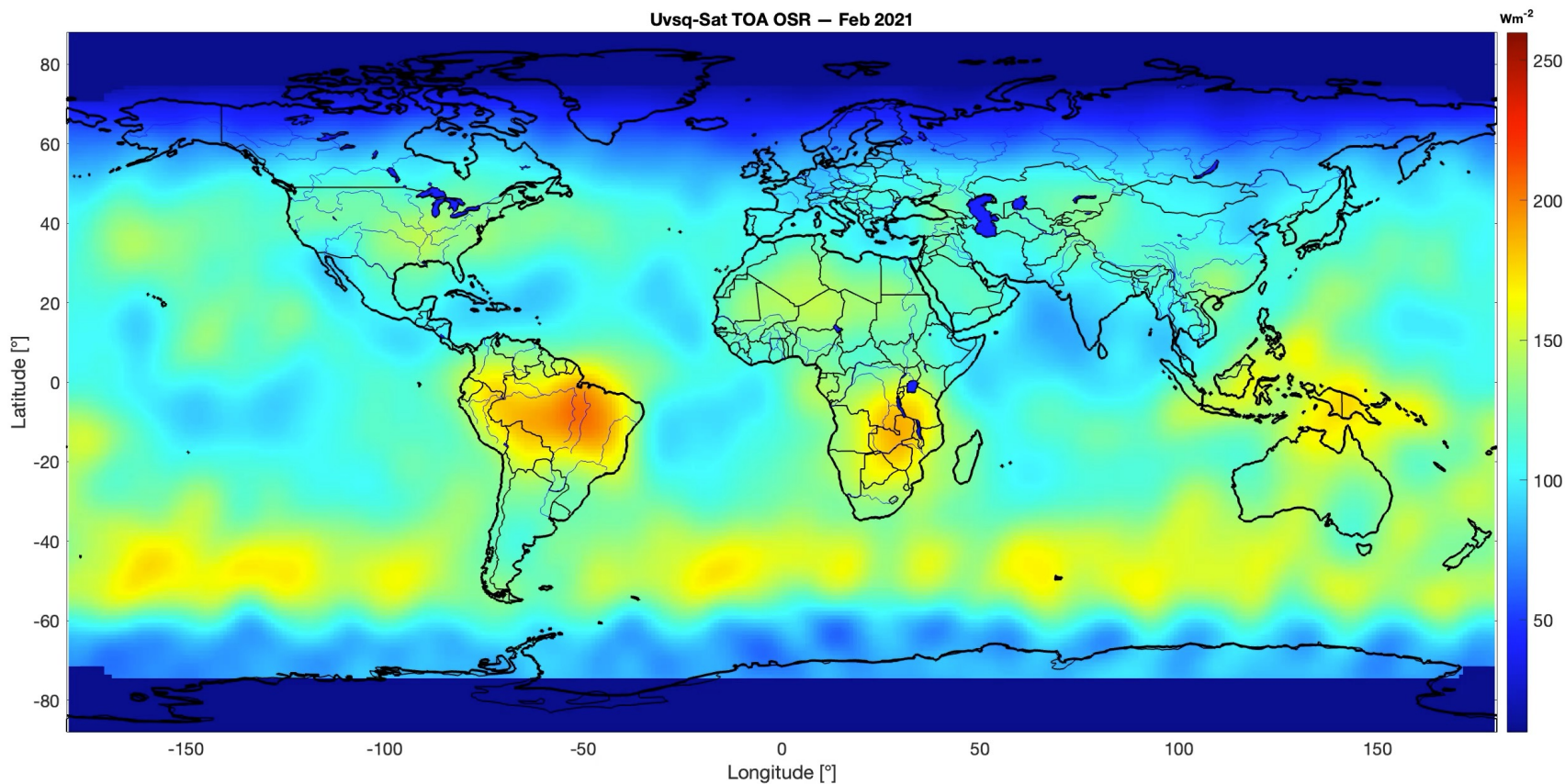

TOA all-sky longwave (LW) flux from Uvsq-Sat

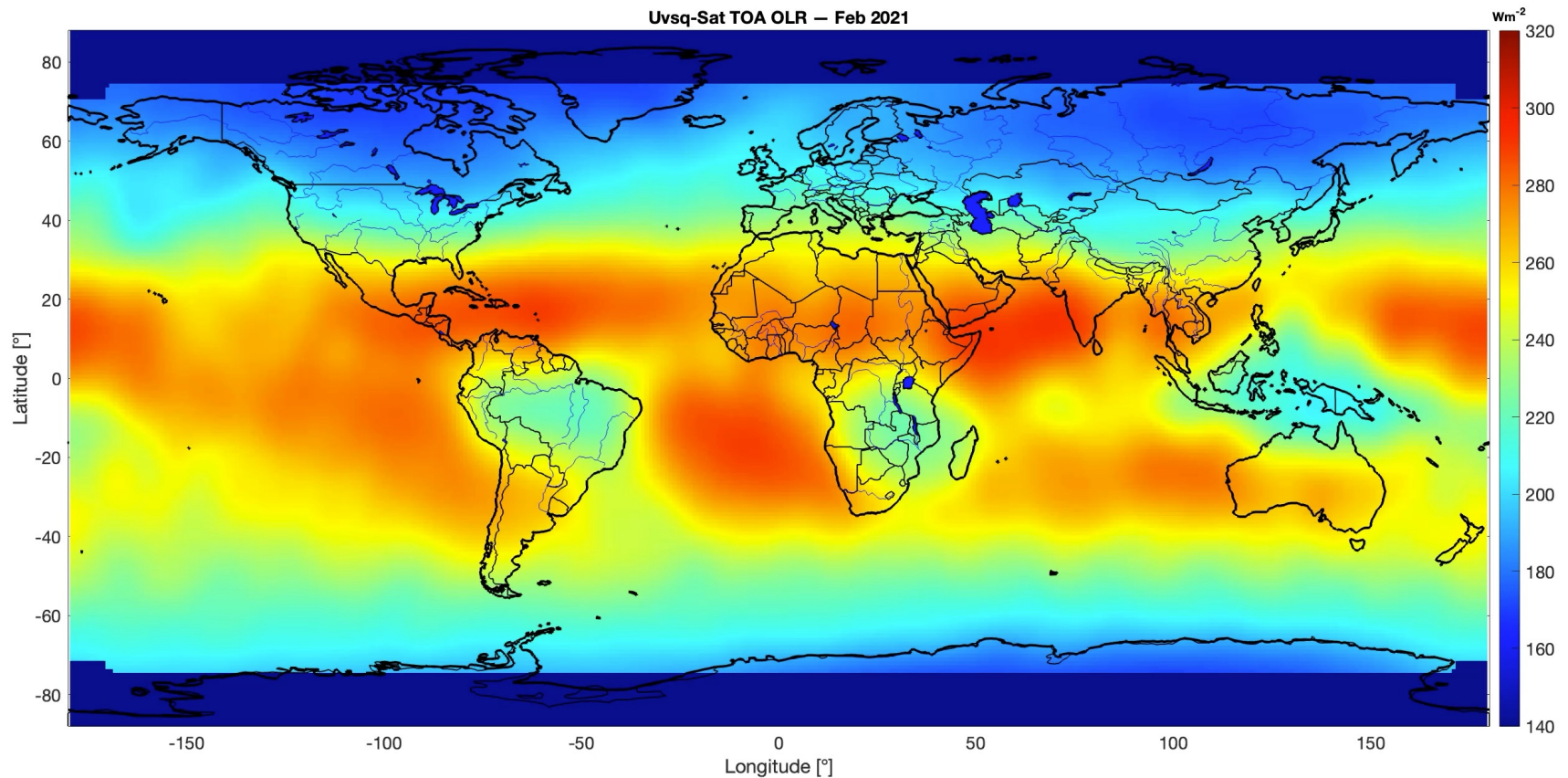

LW flux from GEOS-Chem

OLR – 01/10/2025 00H00

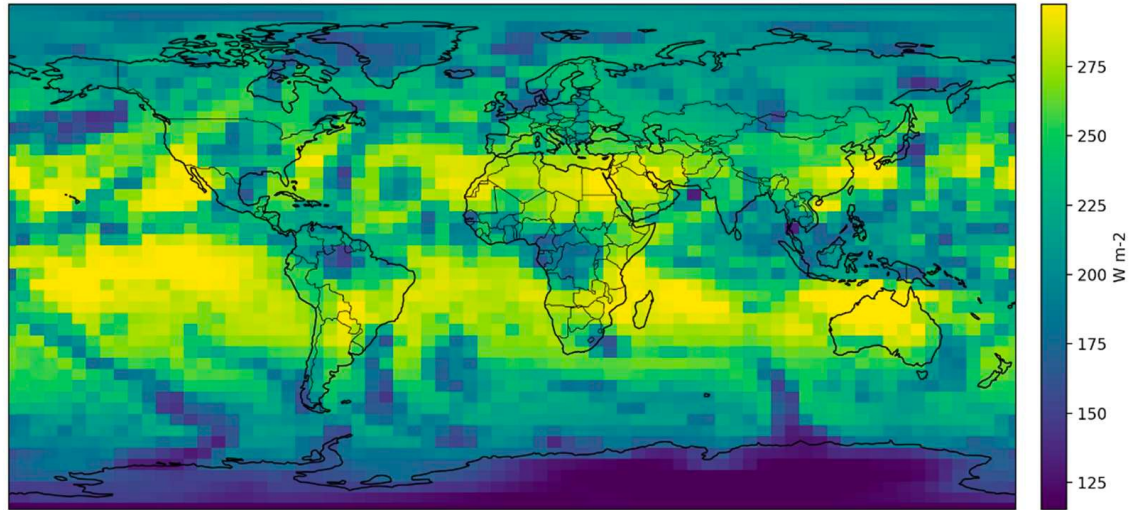

OLR – 01/10/2025 12H00

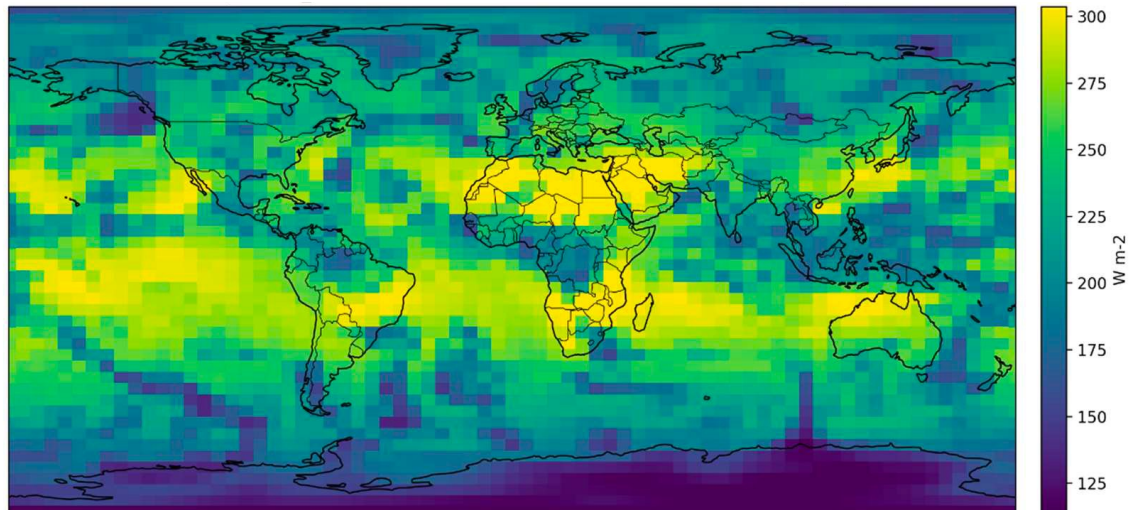

12-month running means of global relative anomalies in ERB

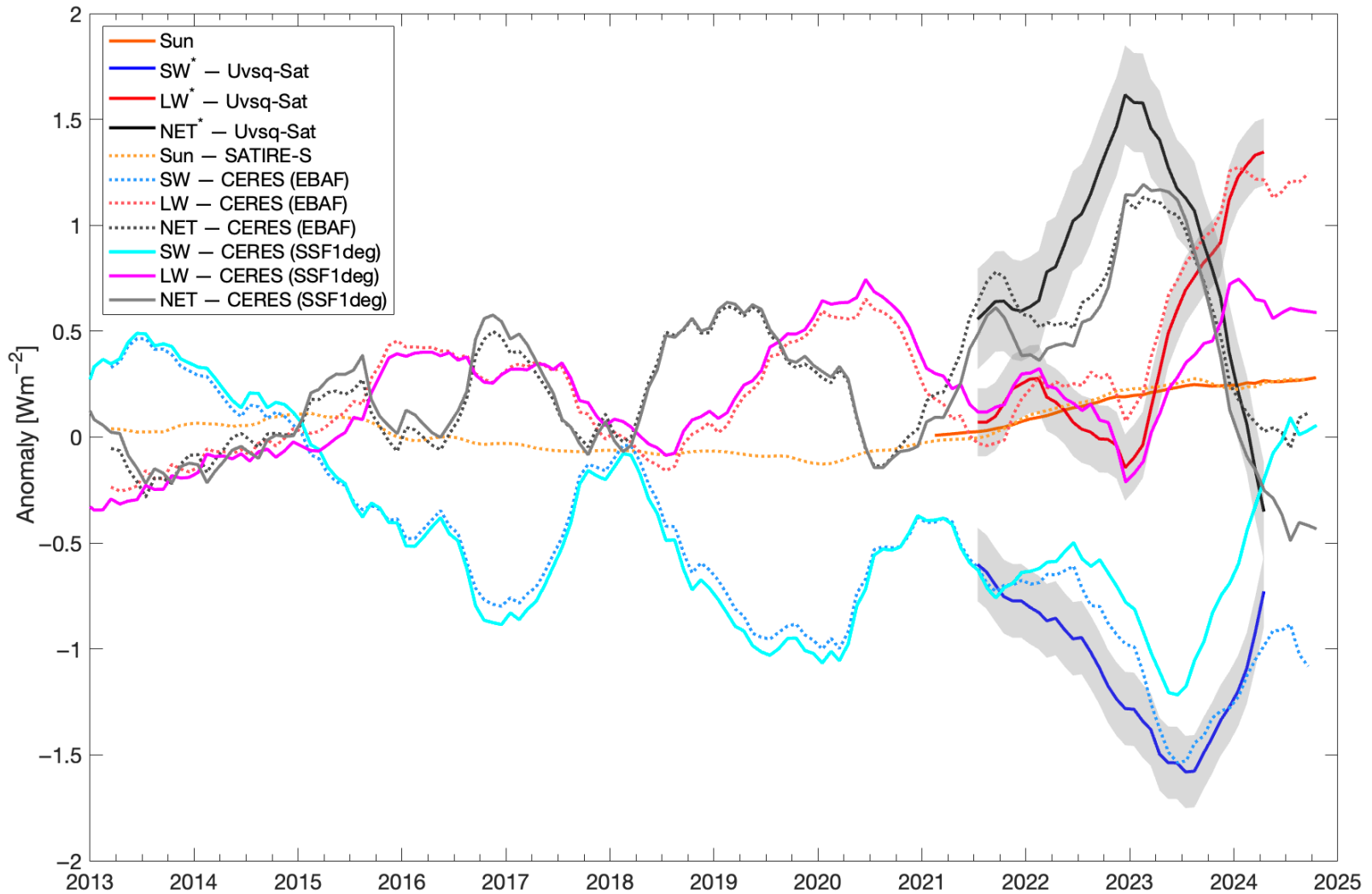

12-month running means of EEI anomalies

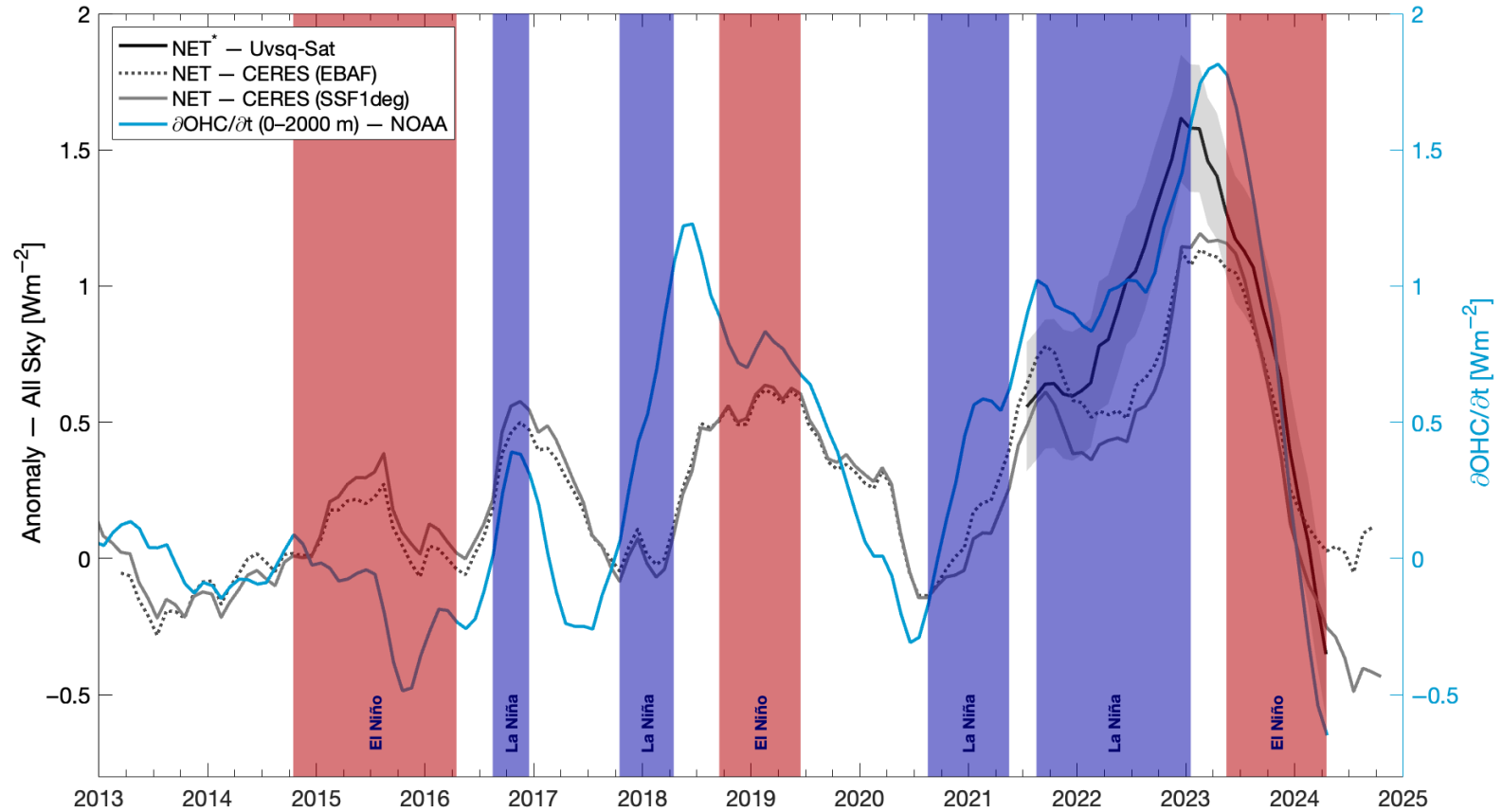

Earth Radiation Portal

Earth Radiation Portal

Remote Sensing Data - LATMOS



[Home](#)

[About Satellites](#)

[Satellites Datasets](#)

[Visual Data Streams](#)

[Credits](#)

[Contact](#)

LATMOS Satellites Data

The Laboratoire Atmosphères, Milieux, Observations Spatiales (LATMOS) is a French research laboratory specializing in atmospheric and space science.

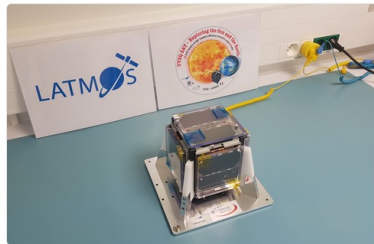

UVSQ-SAT

Launch Date: January 24, 2021. Mission: Earth Radiation Budget (ERB) and solar spectral irradiance measurements.

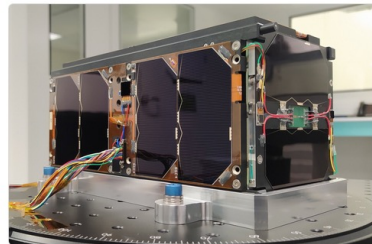

INSPIRE-SAT7

Launch Date: April 15, 2023. Mission: Earth/Sun observations and ionosphere probing, with amateur radio integration.

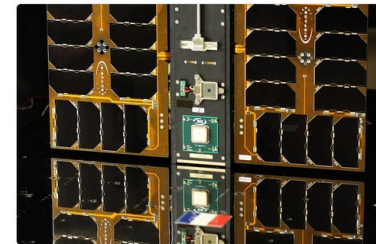

UVSQ-SAT NG

Launch Date: March 15, 2025. Mission: Advanced Earth Radiation Budget (ERB) and greenhouse gas tracking.

Uvsq-Sat NG, a new CubeSat in orbit since 2025

Uvsq-Sat NG aims:

- To continue the **Earth Radiation Budget (ERB)** research initiated by Uvsq-Sat (launched in 2021) and Inspire-Sat 7 (launched in 2023). It intends to achieve broadband ERB measurements using advanced yet simple technologies.
- **Ensure seamless continuity of Earth Radiation Budget observations** with measurement characteristics consistent with CERES heritage missions.
- To monitor **atmospheric gas concentrations** (CO_2 , CH_4 , H_2O and O_2) on a global scale and explore their correlation with Earth's Outgoing Longwave Radiation (**OLR**). Difference between North and South hemispheres.

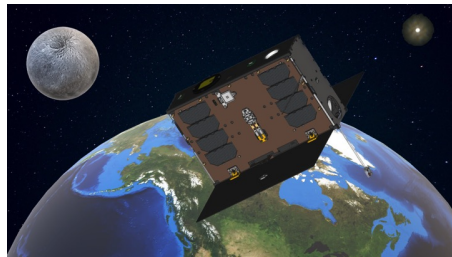

UVSQ-SAT NG (Inspire-Sat X)

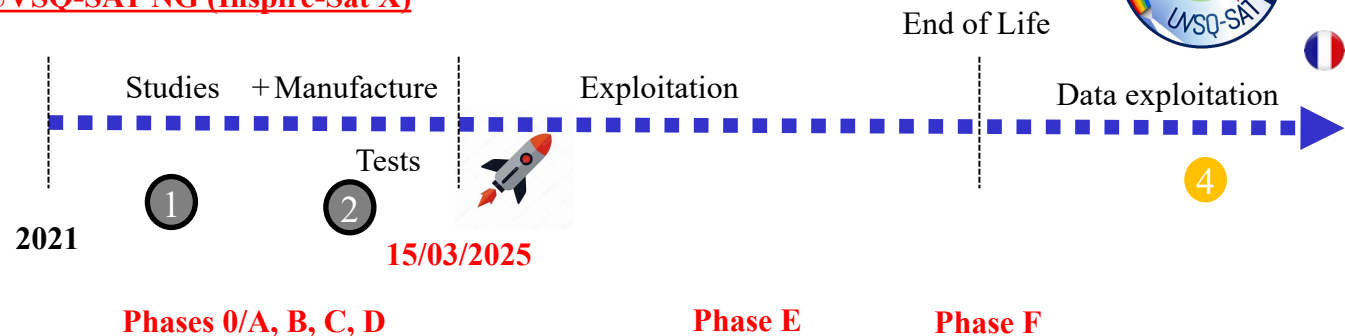

Uvsq-Sat NG a satellite for observing Earth

□ Uvsq-Sat NG mission

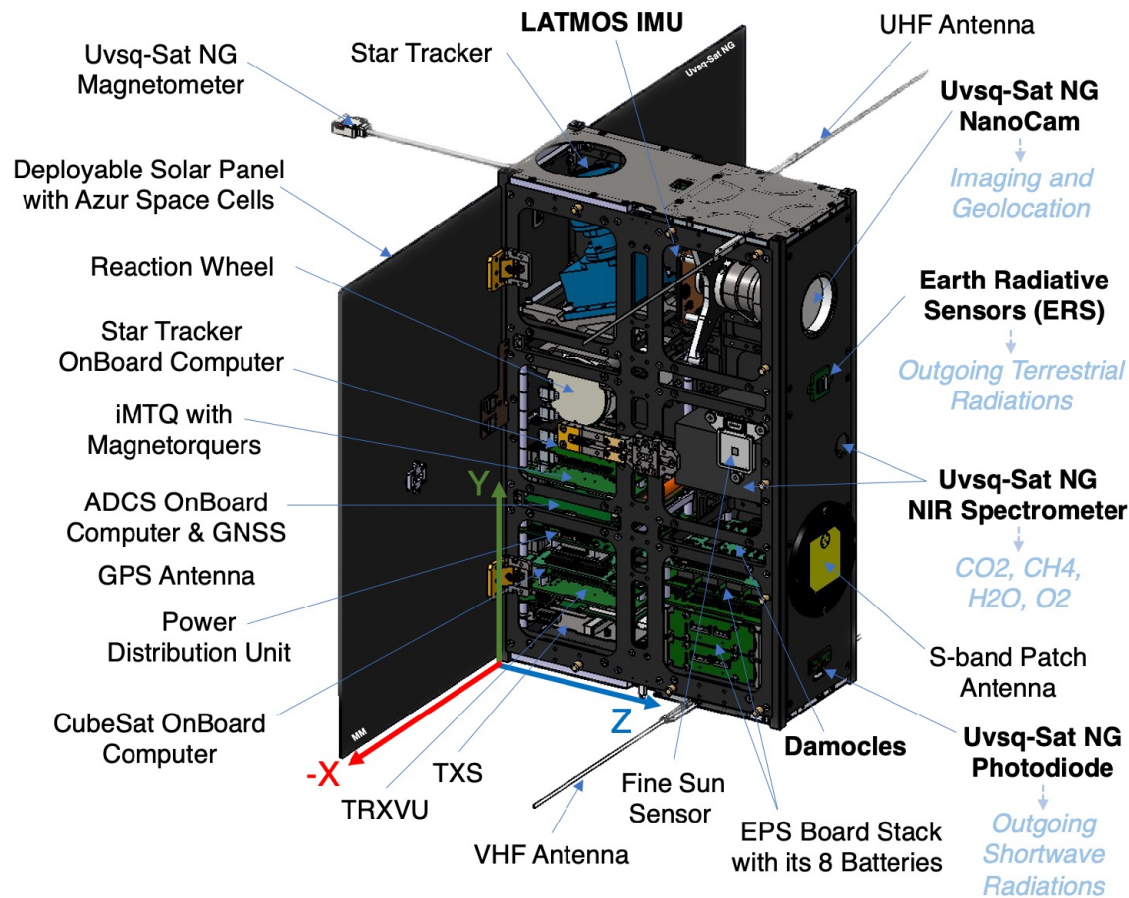

**Uvsq-Sat NG / Inspire-Sat X, a new satellite to envision the space of tomorrow.
An In-Orbit Demonstrator to prepare the SmallSats constellations of the future.**

Uvsq-Sat NG a satellite for observing Earth

□ Type of observations

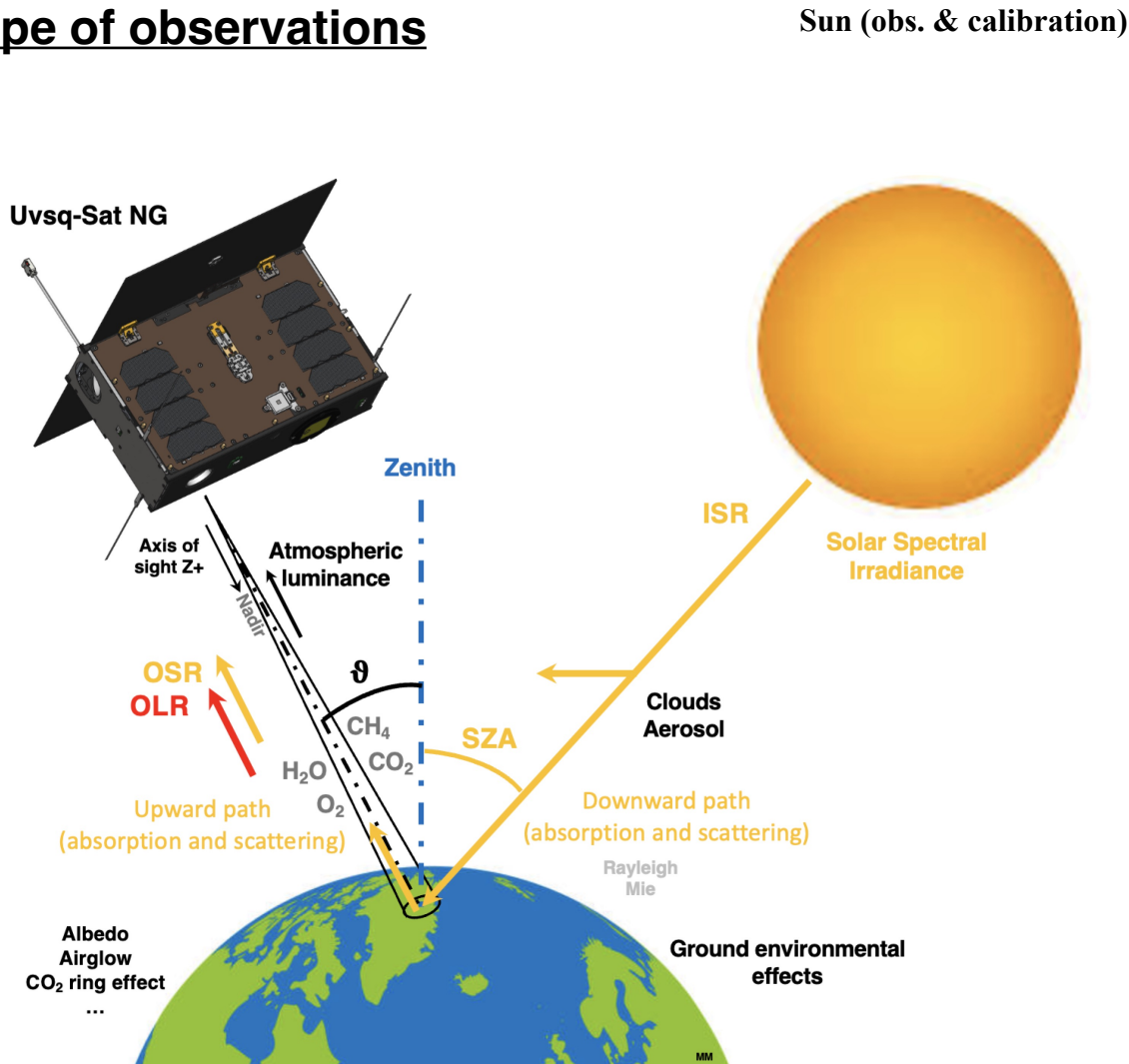

Nadir (over lands)

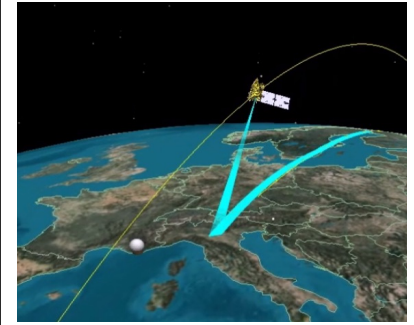

Glint (over oceans)

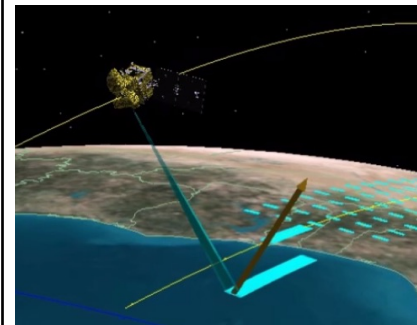

Scan (ground track)

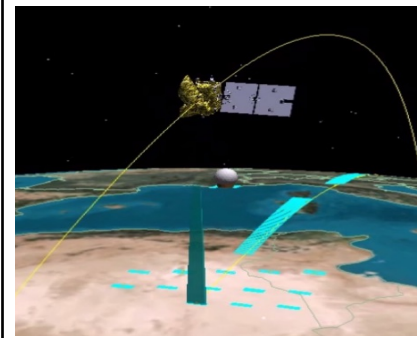

Uvsq-Sat NG a satellite for observing Earth

- We managed the **Uvsq-Sat NG mission end-to-end** — from defining the **scientific requirements** and securing **funding**, to the **design, implementation, and operation** of both the **space and ground segments**.
- This included **launcher selection and launch campaign management**, as well as full compliance with **space debris mitigation and orbital safety regulations (french & international laws)**, leading up to the **successful exploitation of the scientific data**.

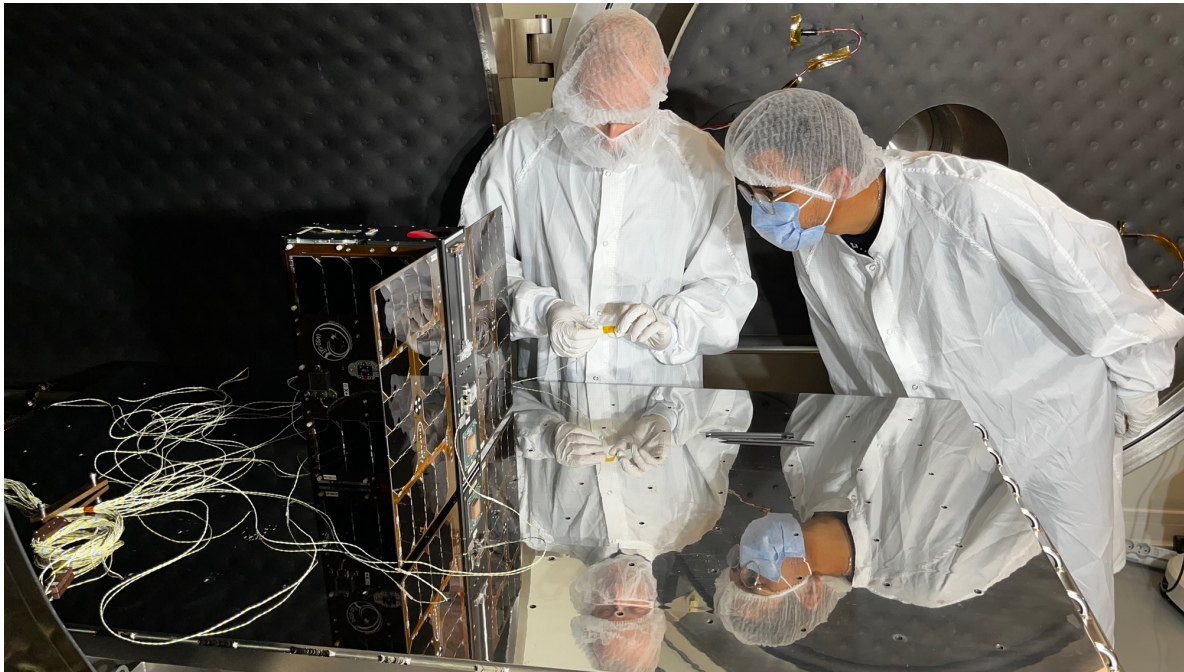

Uvvsq-Sat NG a satellite for observing Earth

□ Design

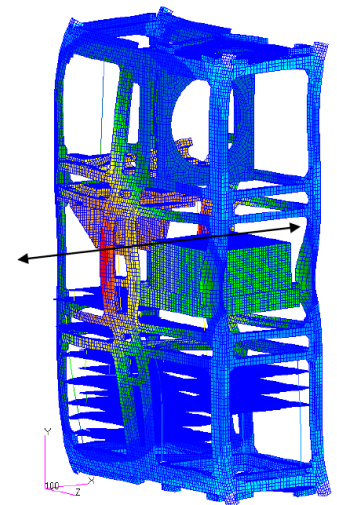
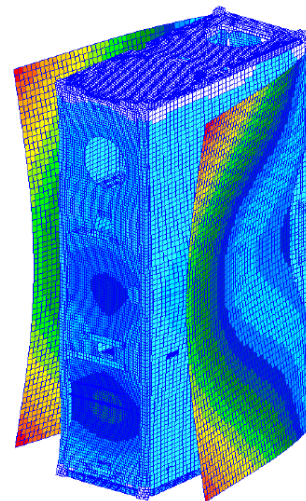
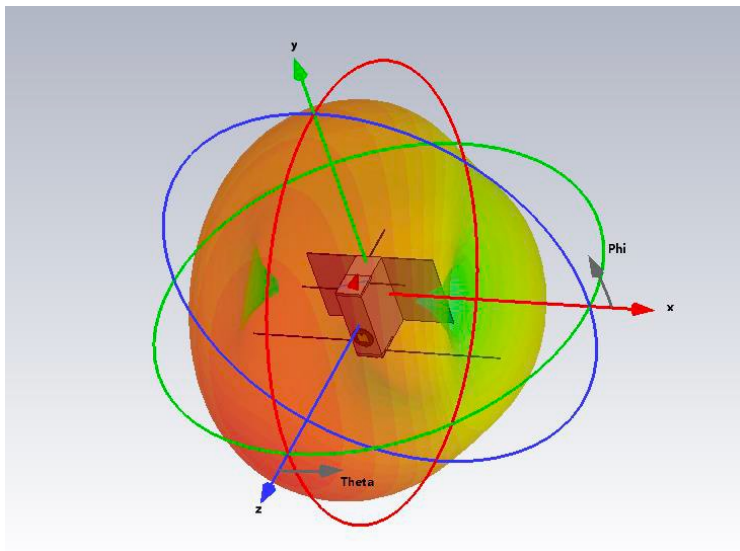
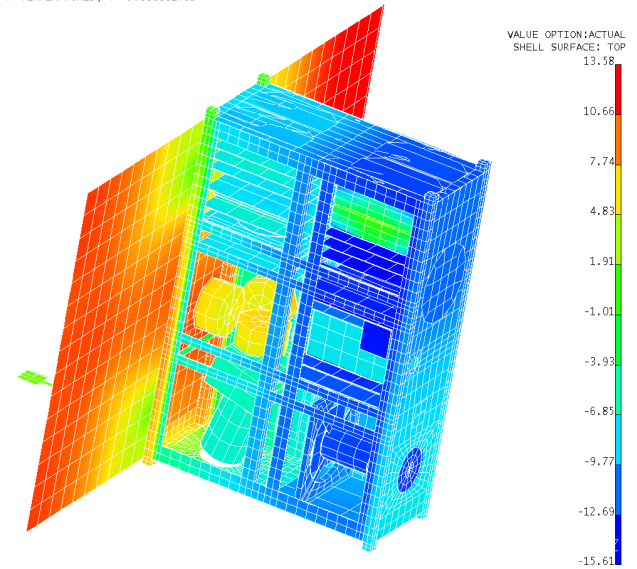
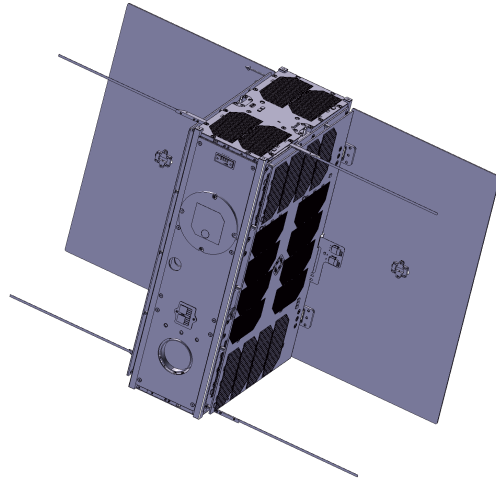
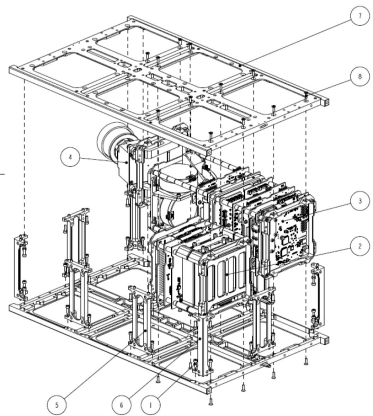

Uvsg-Sat NG a satellite for observing Earth

□ Assembly & Integration

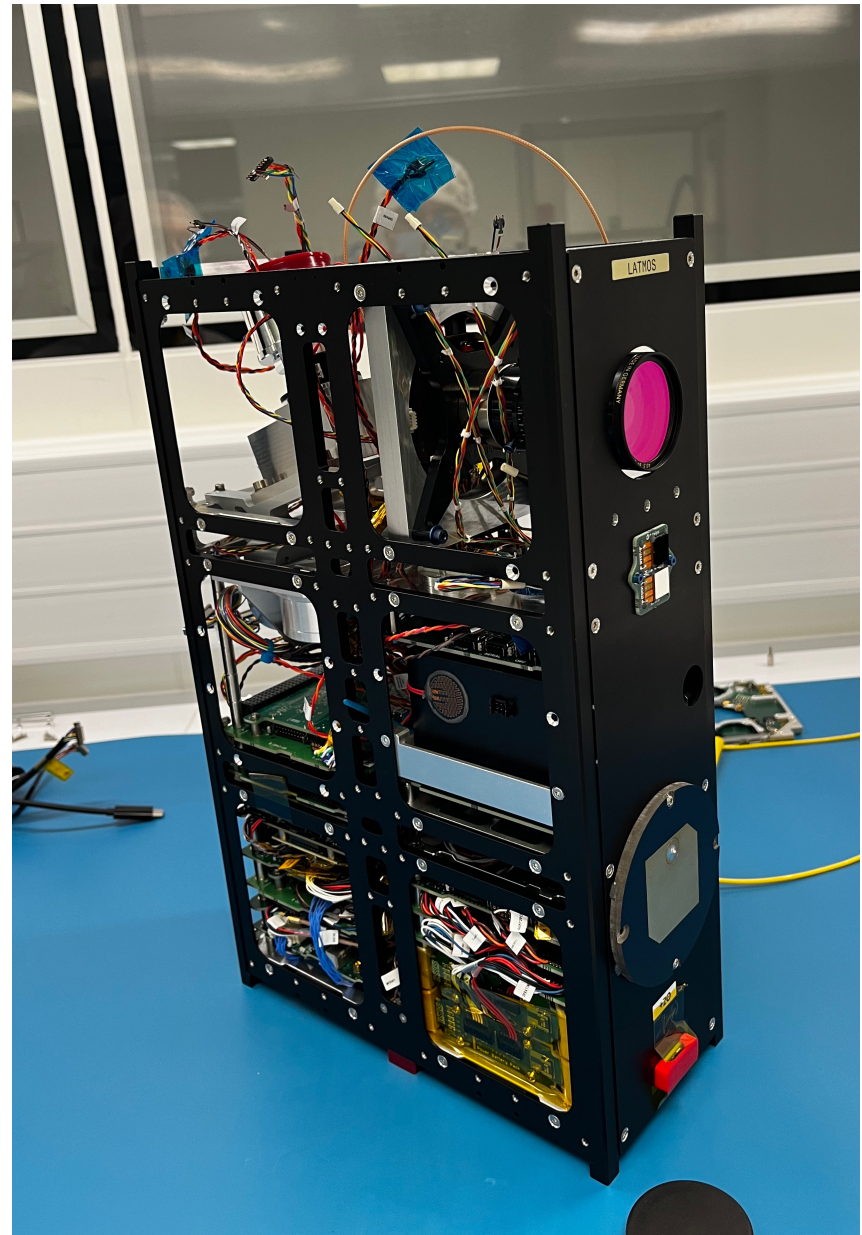
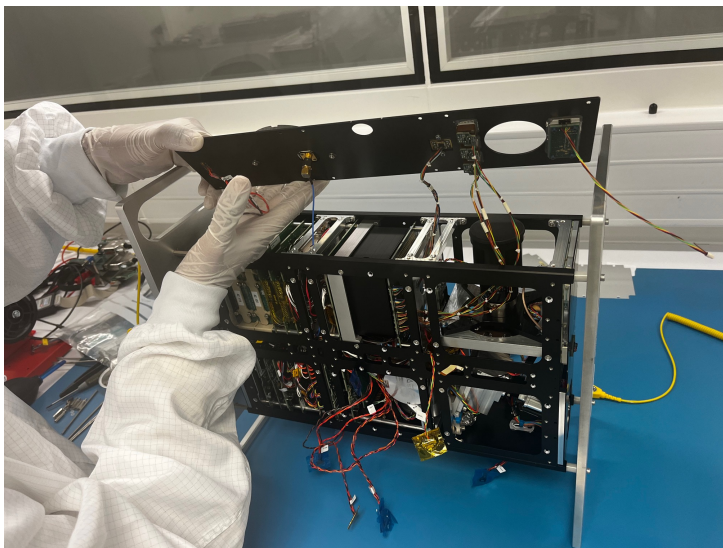
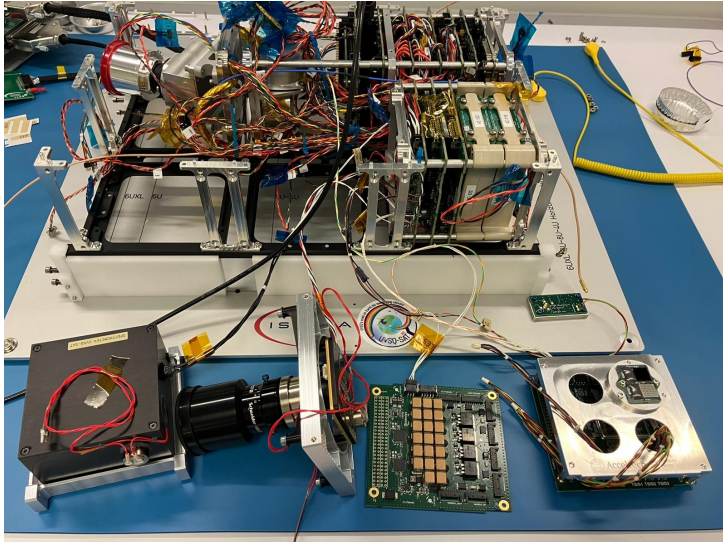

Uvsq-Sat NG a satellite for observing Earth

□ Tests & Calibrations

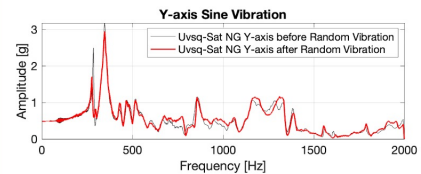
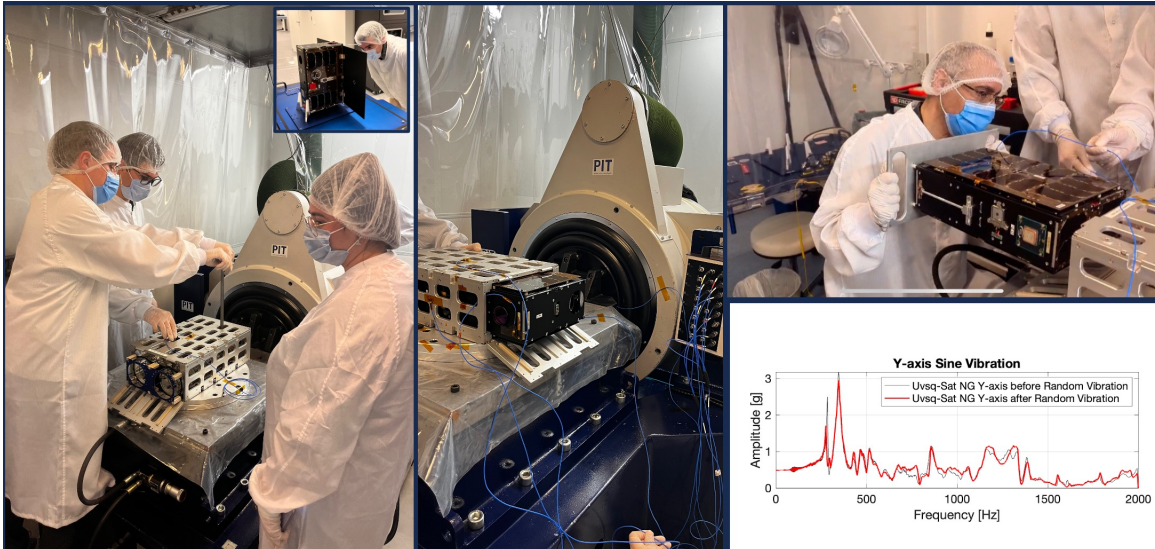
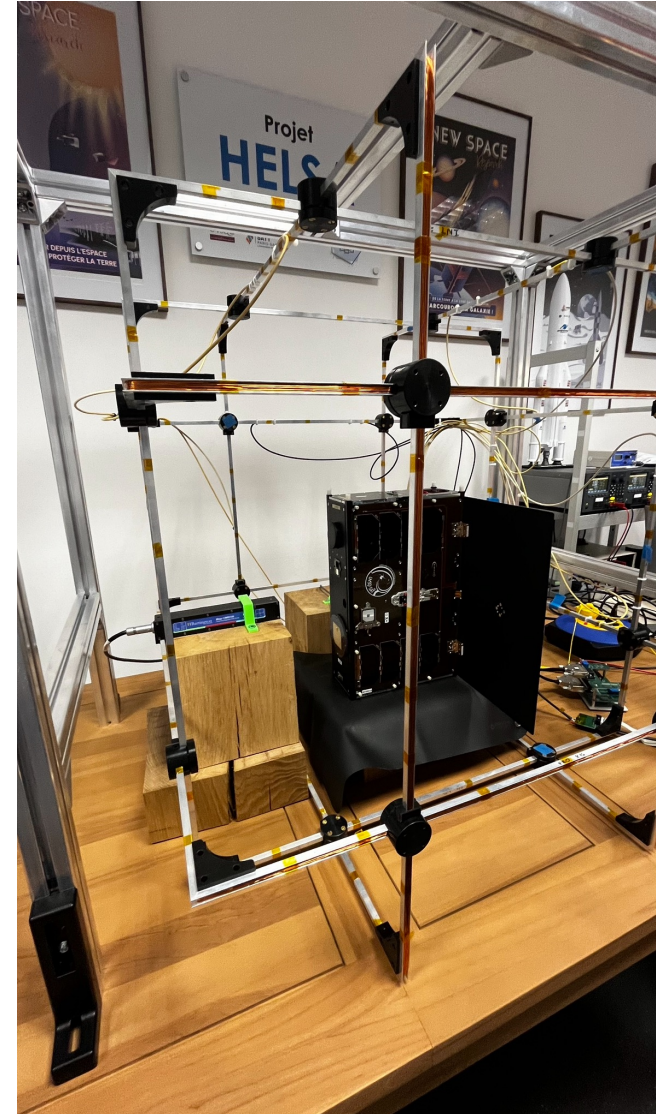

Uvsq-Sat NG a satellite for observing Earth

☐ Tests & Calibrations

The screenshot displays the Stellaris software interface. The main window shows a star field with a mouse cursor pointing to a star. The interface includes several control panels:

- Viewer Star highlighter:**
 - Database: starCatalogue.txt (Browse)
 - Magnitude threshold: 14.00 (Set magnitude threshold)
 - Latitude (deg): 48.812995
 - Longitude (deg): 2.23847 (Set Earth Location)
 - Field of view: Screen height (m): 1.00, Distance to screen (m): 0.32, FOVy (deg): 114.25 (Set field of view)
 - Date and Time (UTC+0): 01/02/23 00:49:56, 31/12/2022, 23:00:00 (Set Date)
 - Look at (deg): ICRF, AltAz (Look at)
 - Rotation speed factor: 351 (Set rotation speed factor)
 - Stars' size: Slider, ICRF, AltAz, Horizon
 - Full screen (F11), About
- About dialog:**
 - Stellaris - Star simulator
 - Version 1.0
 - Contact : Mustapha.Meftah@latmos.ipsl.fr

The desktop background features a desert landscape with saguaros. The taskbar shows icons for Parallels Transport..., Capture d'écran 2..., Capture d'écran 20..., HxD, WS, HMI Analyser, BRDF, Capture d'écran 20..., and Stellaris.

Uvsq-Sat NG a satellite for observing Earth

□ Final integration

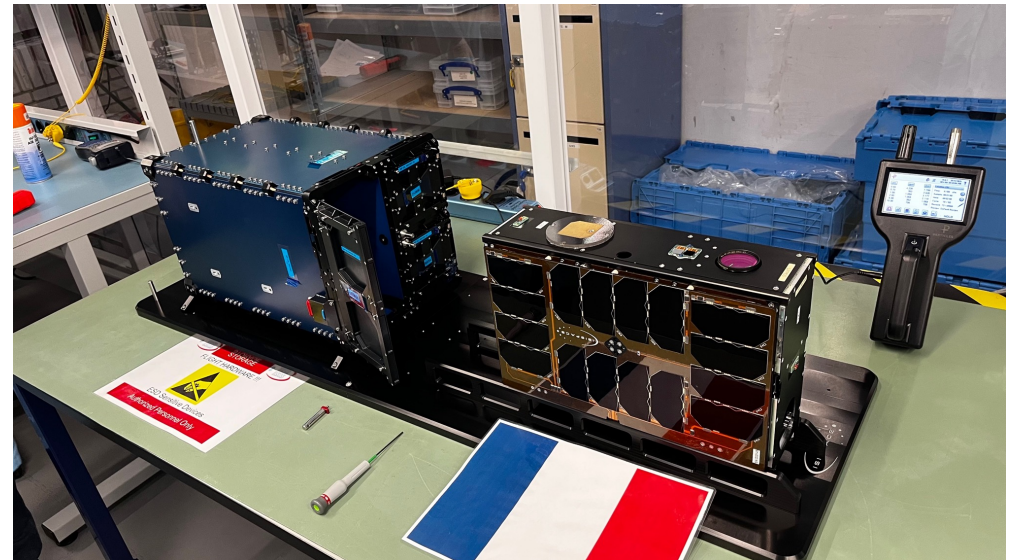
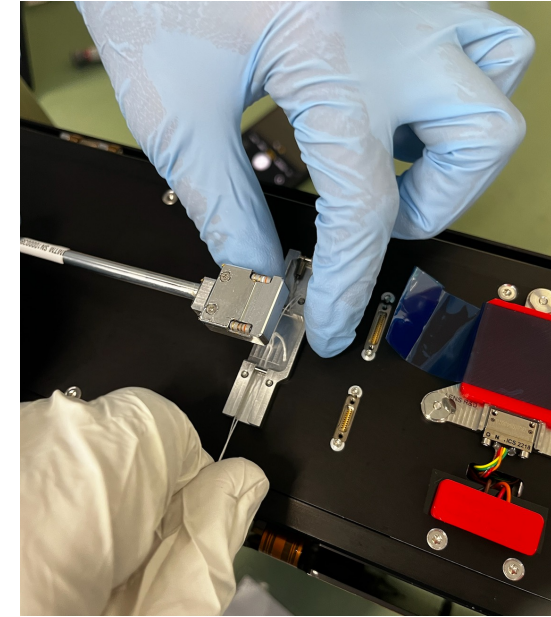
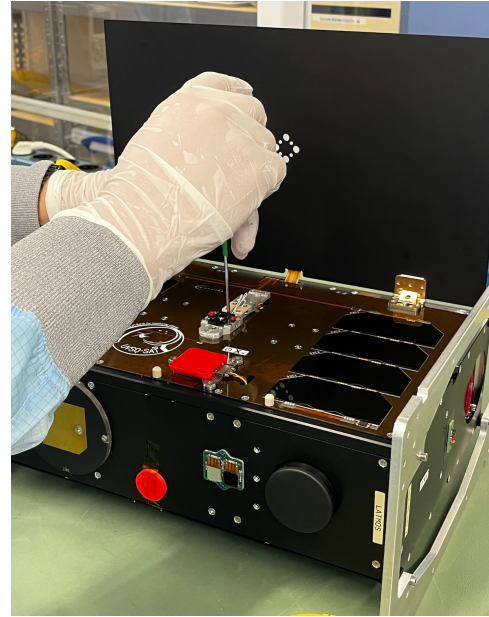
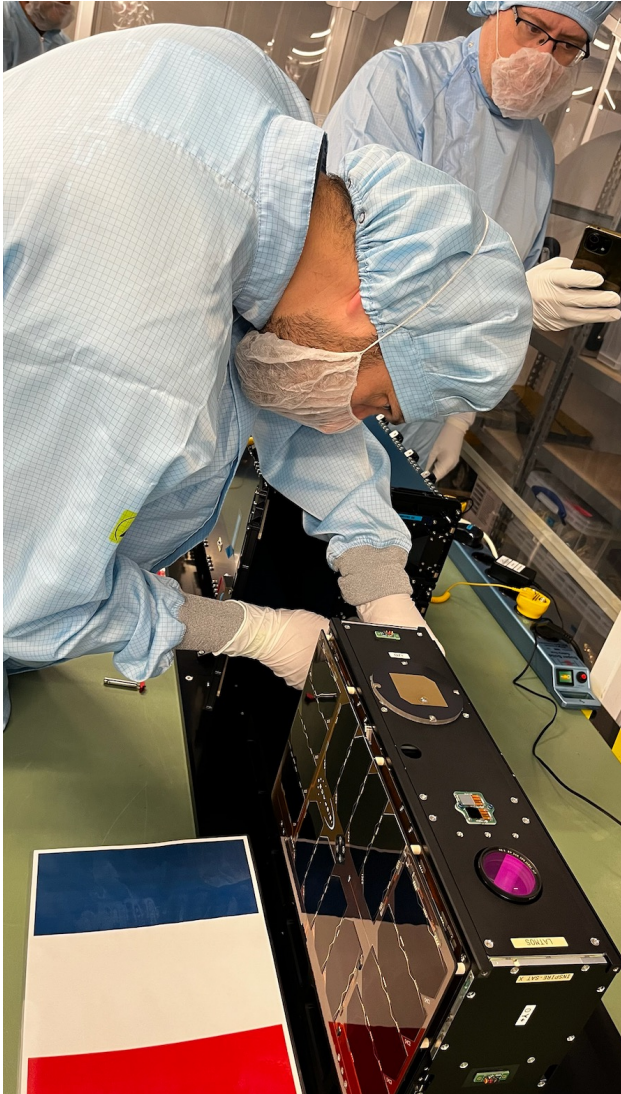

Uvsg-Sat NG a satellite for observing Earth

□ Launch campaign

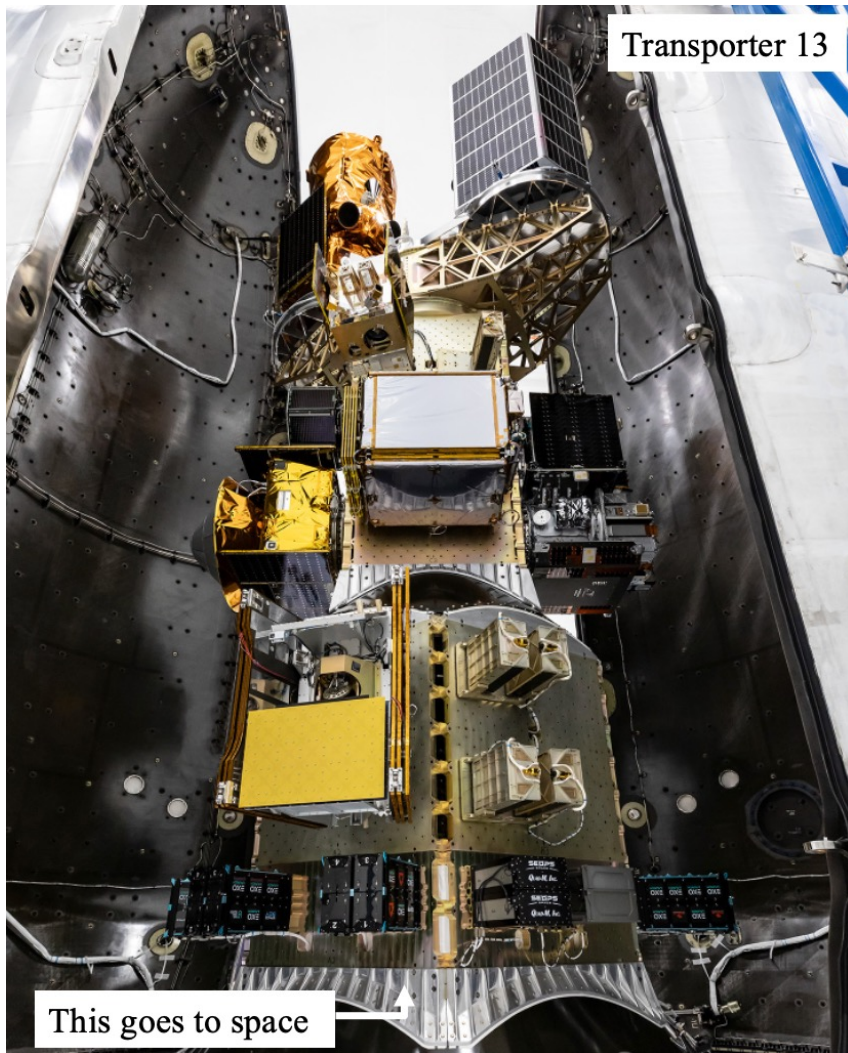

*Mission launched
in March 2025*



Uvsg-Sat NG a satellite for observing Earth

□ Launch

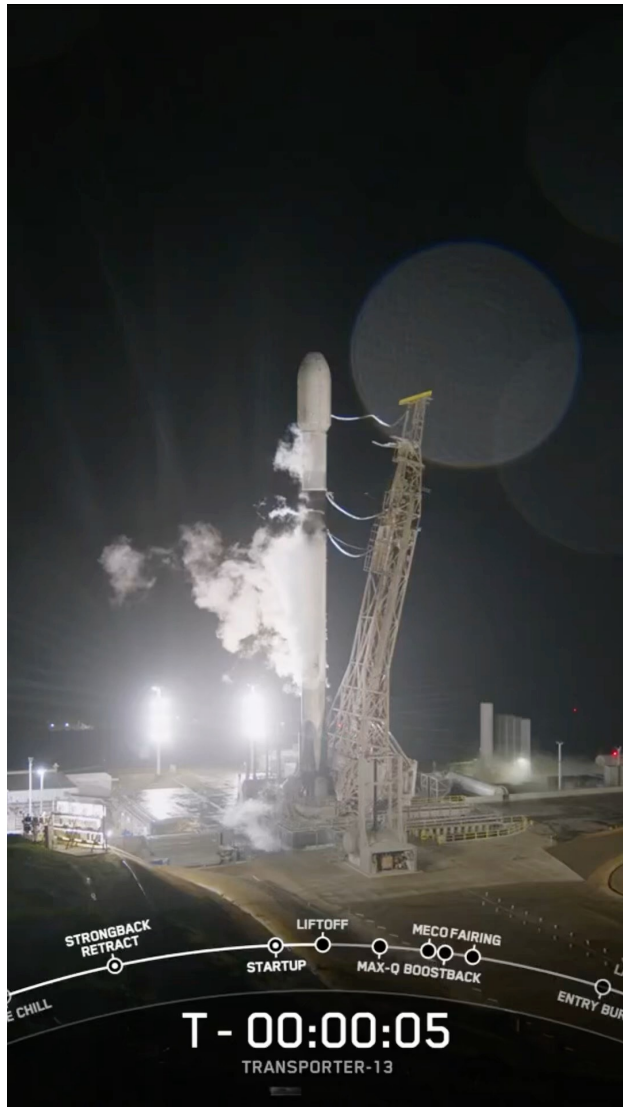

Uvsq-Sat NG a satellite for observing Earth

□ MOC & Telemetry

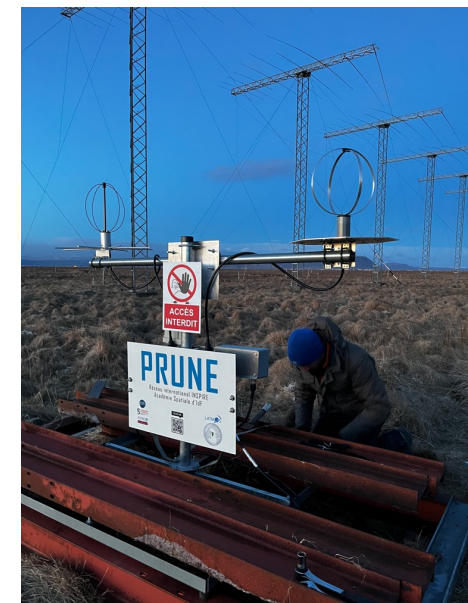
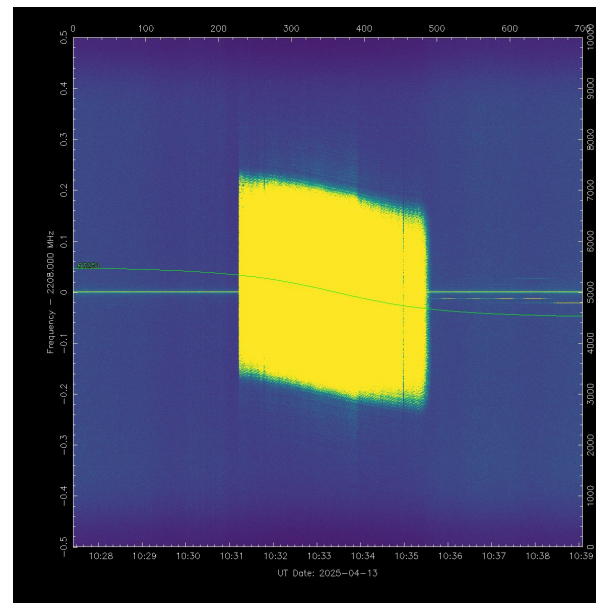
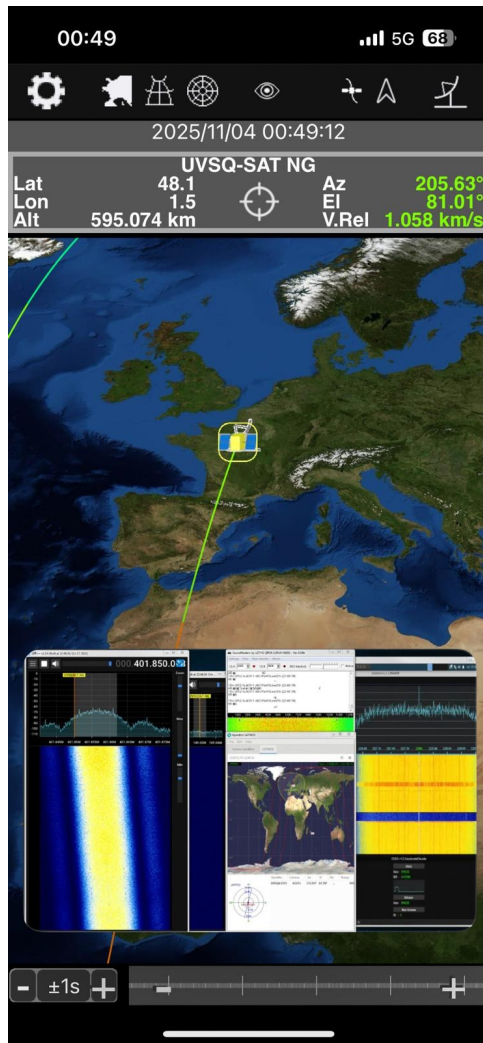

Uvsq-Sat NG a satellite for observing Earth

□ MOC & Telemetry

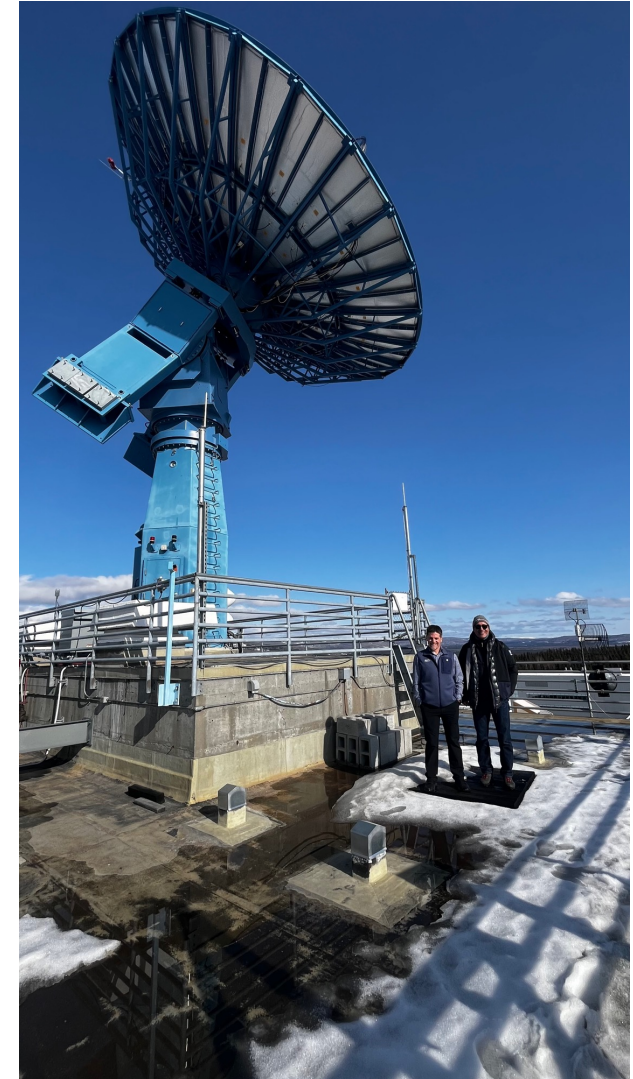
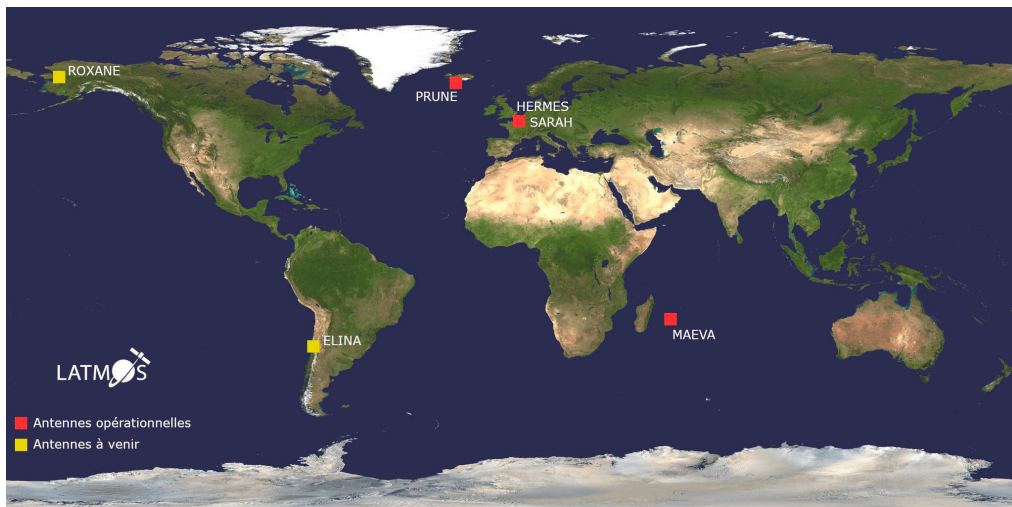
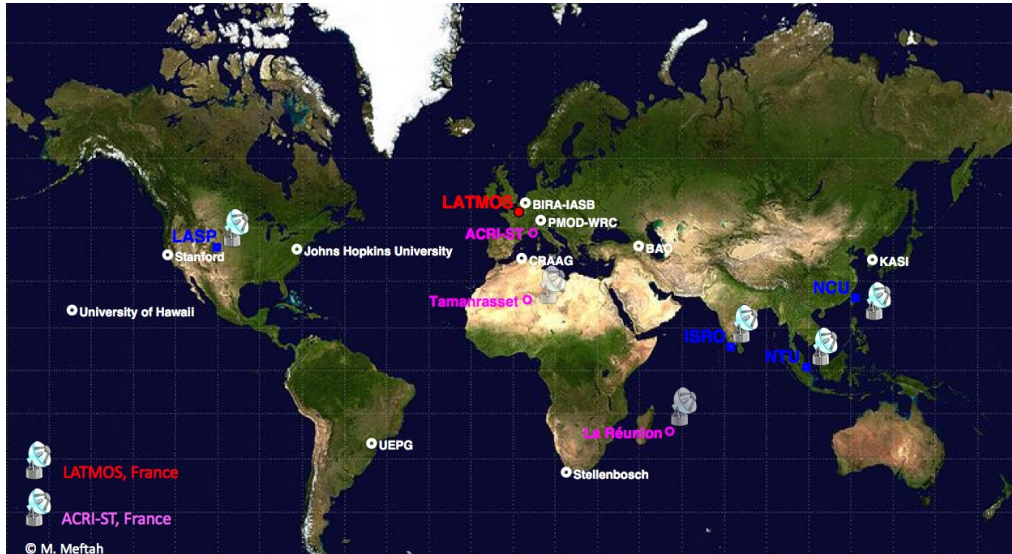

Uvsq-Sat NG a satellite for observing Earth

☐ Calibration in orbit → Work in Progress

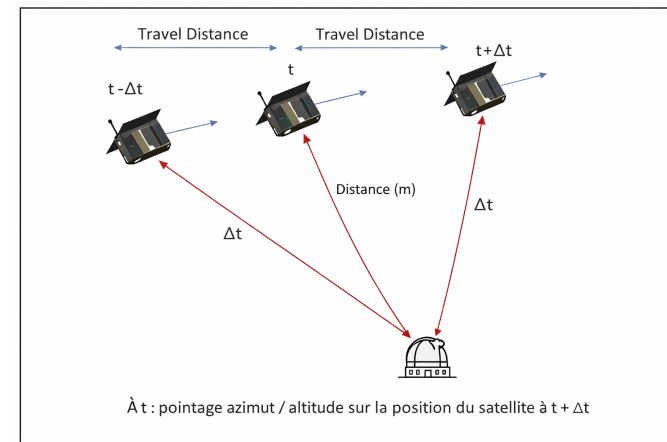
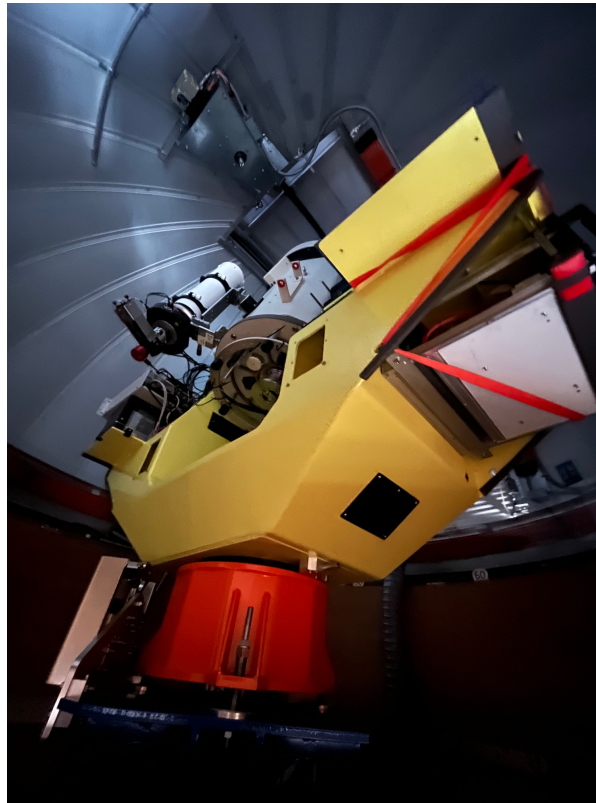

Uvsq-Sat NG a satellite for observing Earth

□ Data

T°C

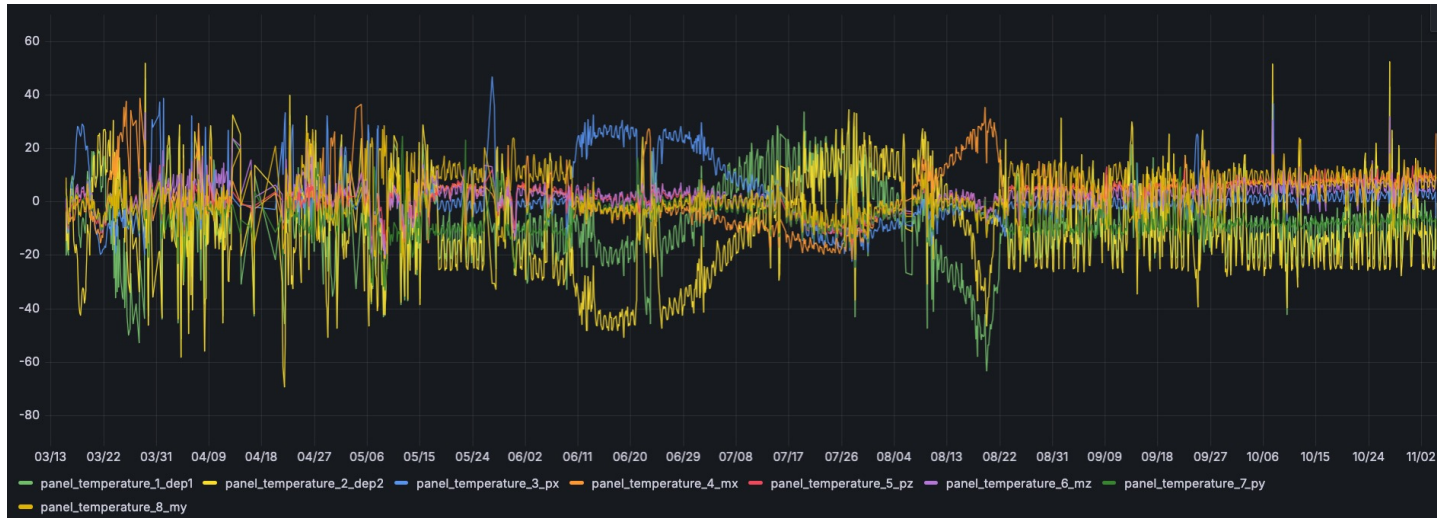

Voltage

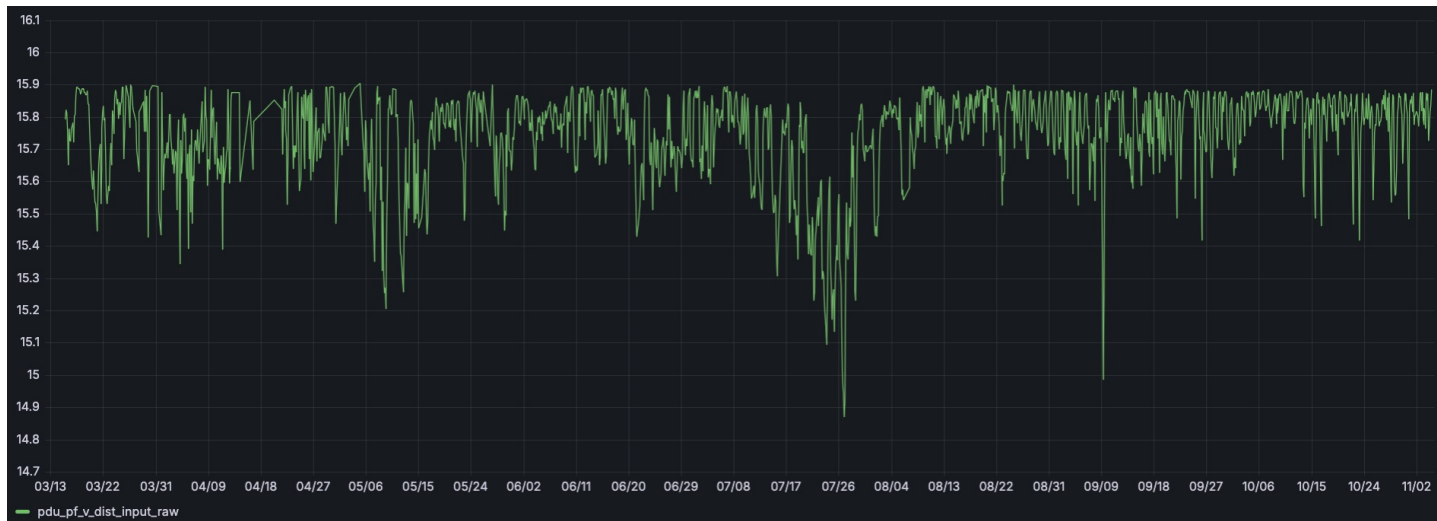

Uvsq-Sat NG a satellite for observing Earth

□ Data

T°C

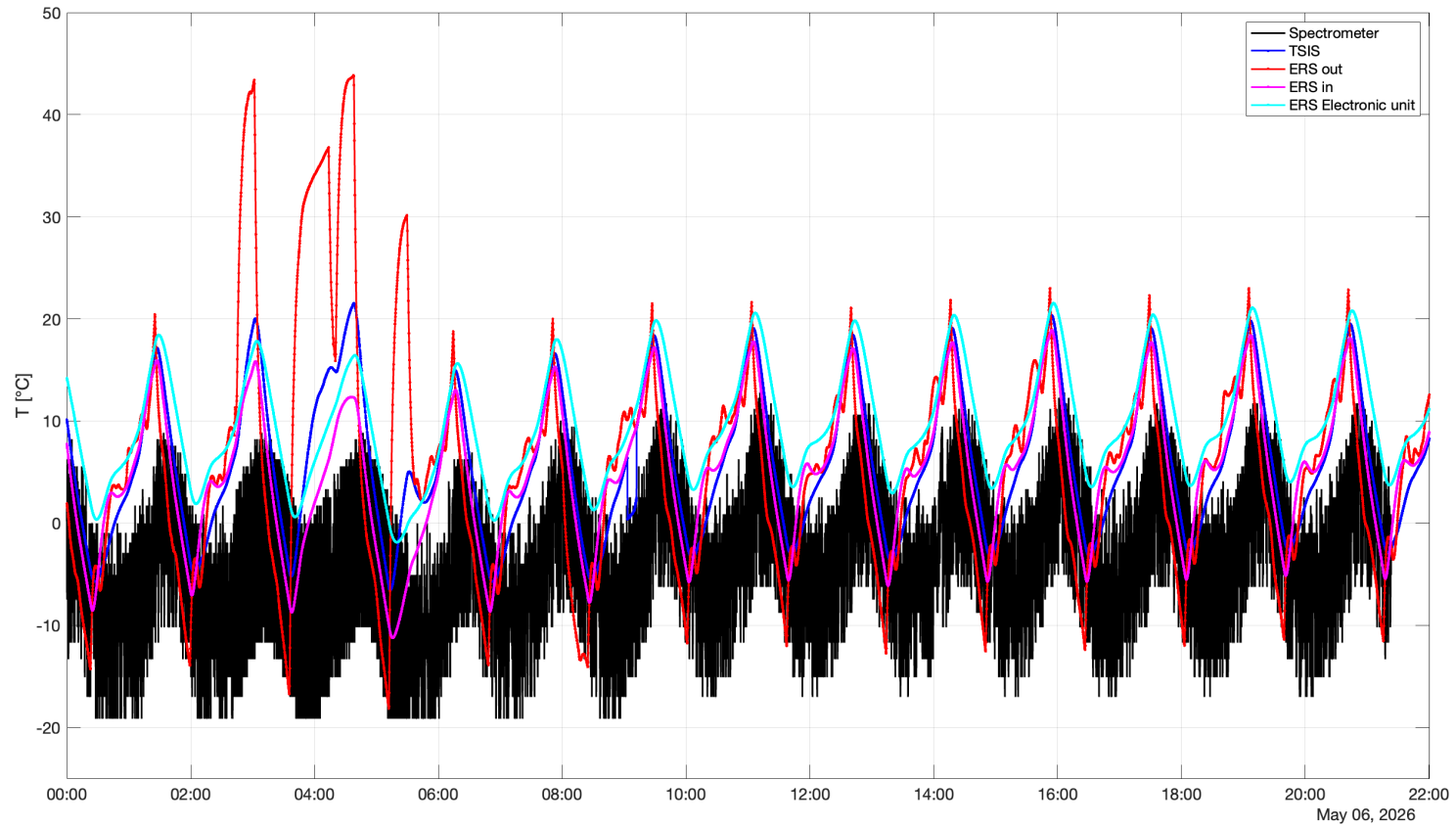

Uvsg-Sat NG a satellite for observing Earth

□ Data

● IMU

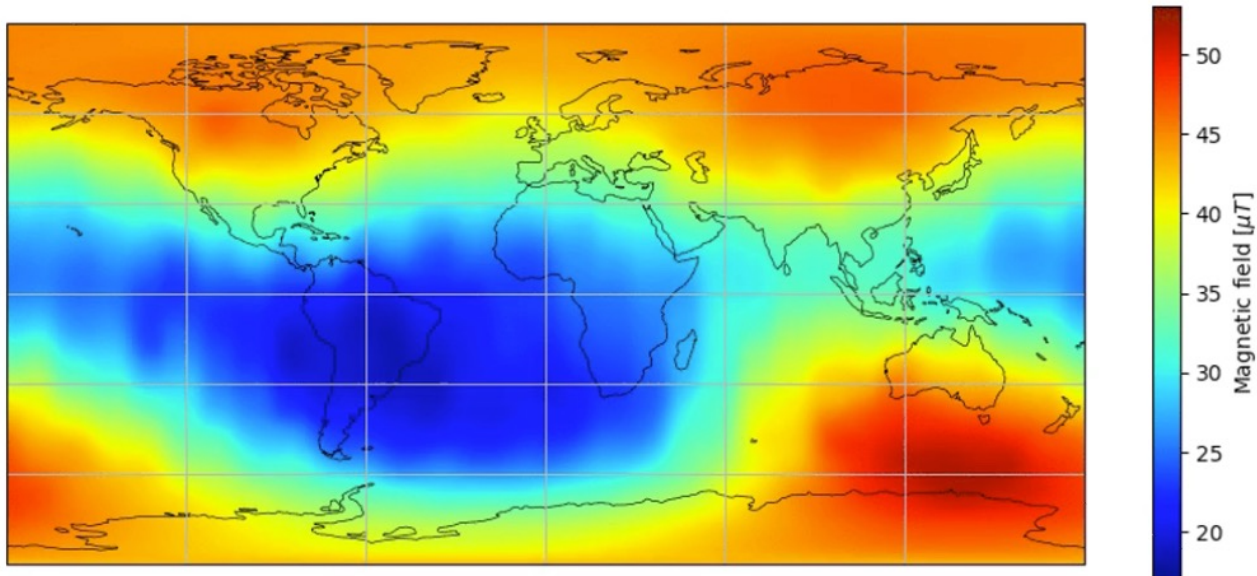

Uvsq-Sat NG a satellite for observing Earth

□ Accuracy of the AOCS

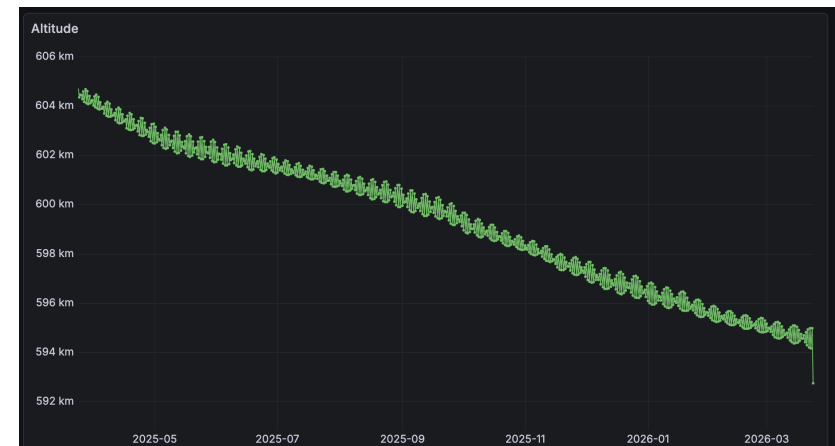
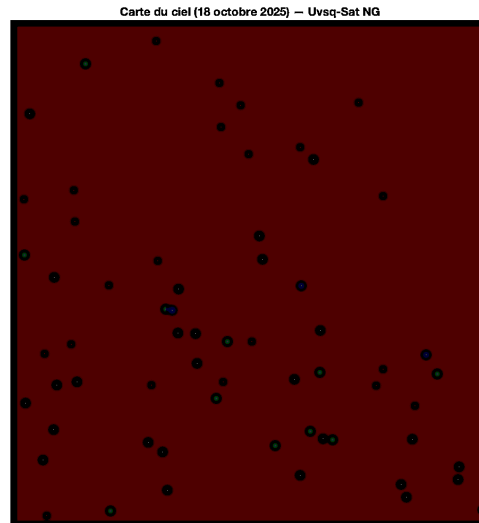
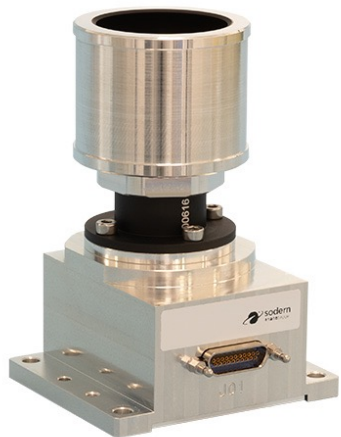

Uvsq-Sat NG a satellite for observing Earth

☐ Images → OK

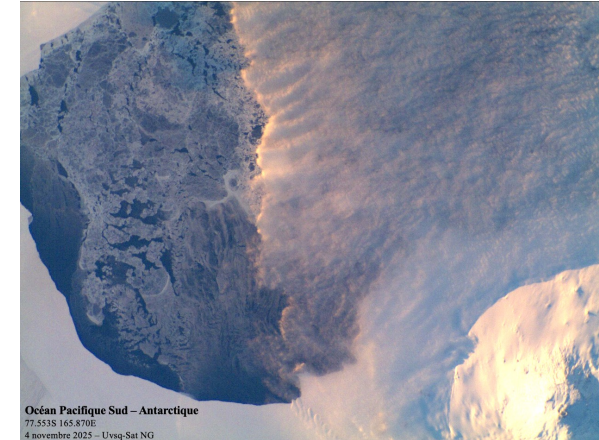
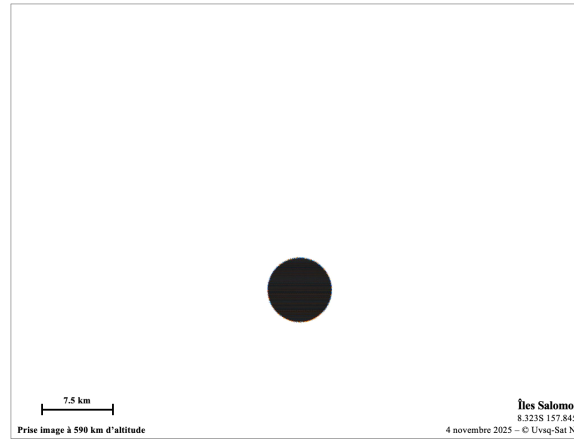

Uvsg-Sat NG a satellite for observing Earth

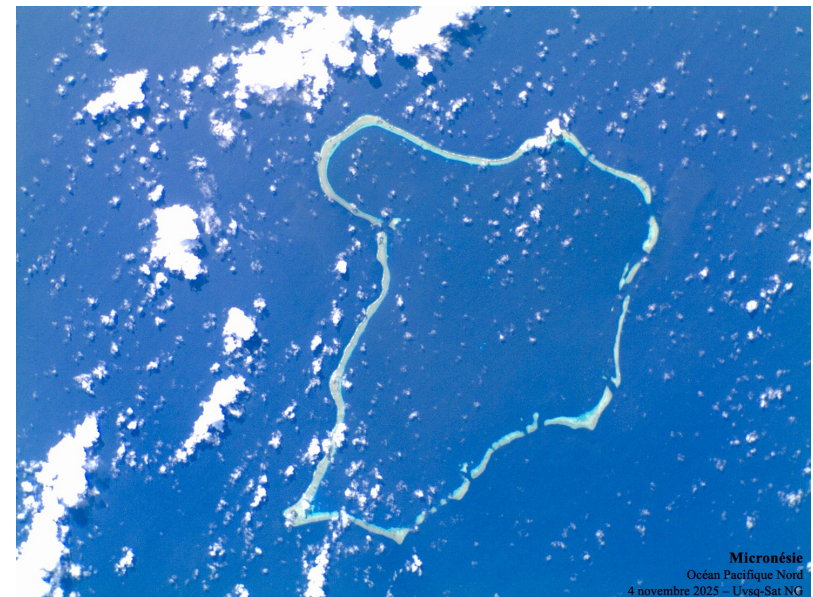
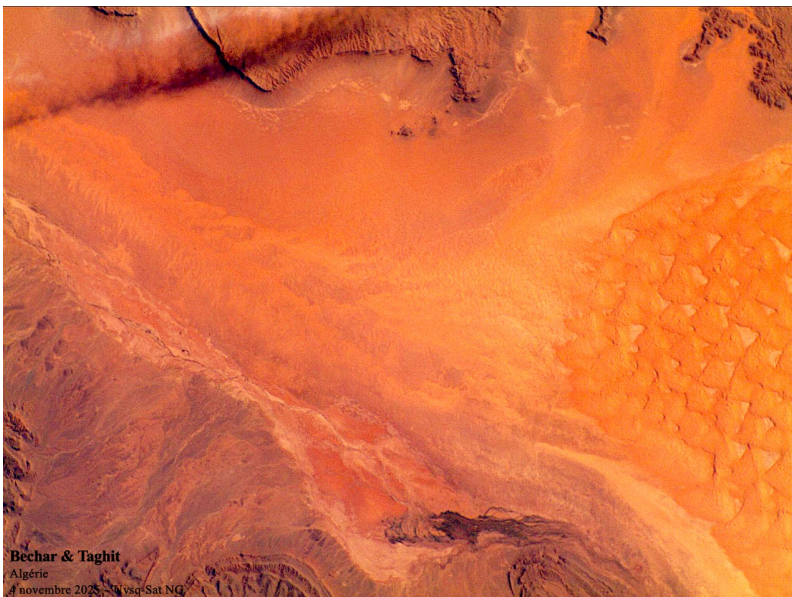
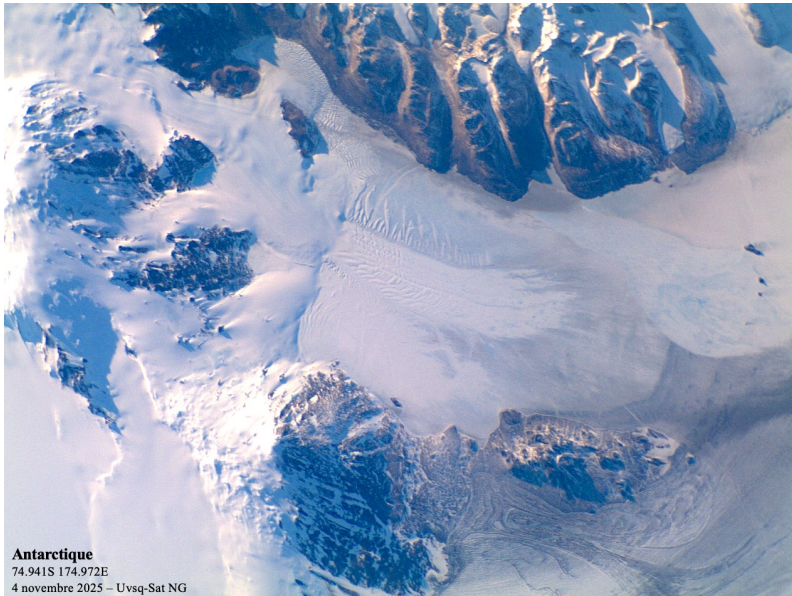

Uvsq-Sat NG a satellite for observing Earth

Les contrails - trainées de condensation

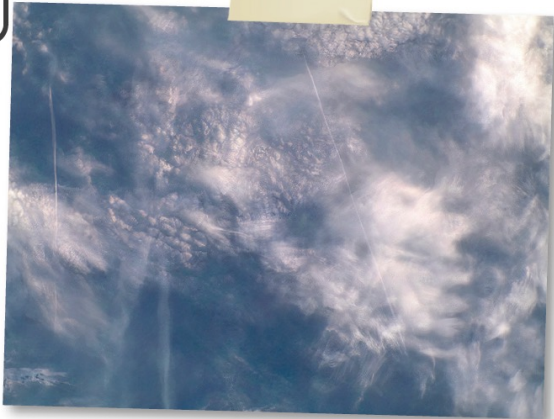

Image prise au-dessus de la Norvège, au nord-ouest de la ville de Porsgrunn et au sud de Kongsberg, à environ 597 km d'altitude. Coordonnées au sol : 59°688'N, 9°41'E. N°06284, 27 octobre 2025.

Au milieu des formes naturelles, certaines signatures artificielles apparaissent aussi sur les images : ce sont les trainées de condensation, ou contrails, laissées dans le ciel par les avions. Ces lignes fines et rectilignes, parfois entrecroisées, se forment lorsque la vapeur d'eau issue de la combustion du kérosène se condense et gèle dans l'air froid de la haute troposphère, entre huit et douze kilomètres d'altitude. À ces altitudes, la température est souvent inférieure à -40 °C, et la saturation en humidité favorise la formation de cristaux de glace. Ces trainées peuvent persister plusieurs heures, se diffuser et, dans certaines conditions, évoluer en voiles de cirrus artificiels.

Longtemps considérées comme un simple phénomène esthétique, les trainées de condensation font aujourd'hui l'objet d'une attention croissante. Leur influence sur le climat, bien que localement modeste, est désormais mesurable. Elles augmentent le forçage radiatif net en réchauffant l'atmosphère : d'une part en réfléchissant peu la lumière solaire incidente, et d'autre part en piégeant efficacement le rayonnement infrarouge émis par la surface. En favorisant la formation de nuages de haute altitude, elles modifient l'albédo, épaississent la couverture nuageuse et peuvent affecter le bilan radiatif régional. Selon les estimations du GIEC, l'aviation civile représente environ 3,5 % du réchauffement climatique global, dont une part notable liée non pas au CO_2 , mais aux trainées persistantes et aux cirrus induits.

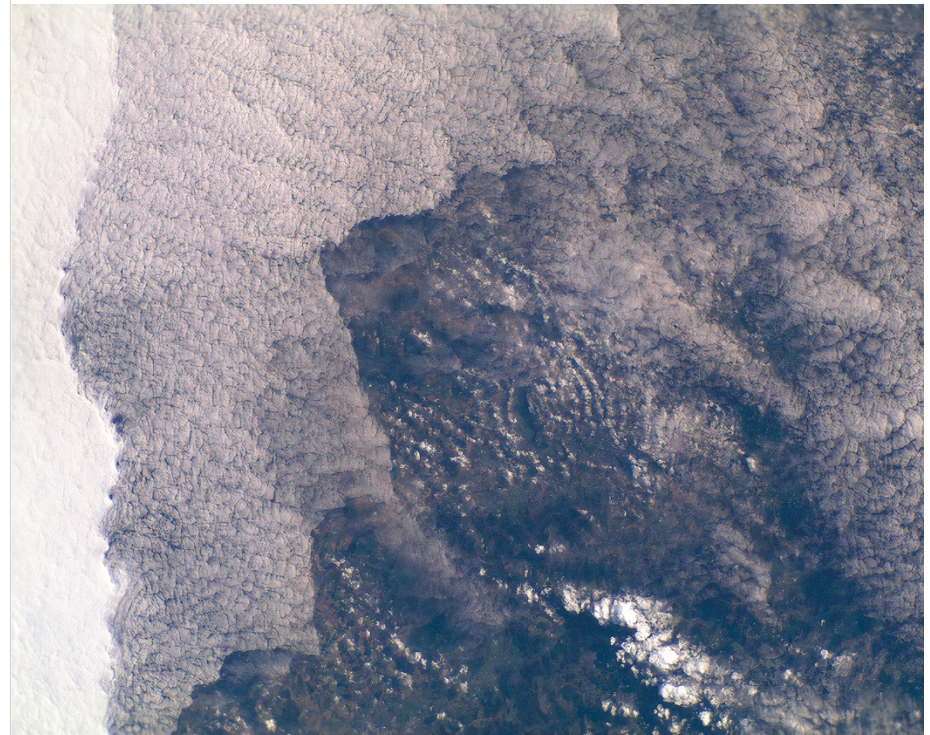
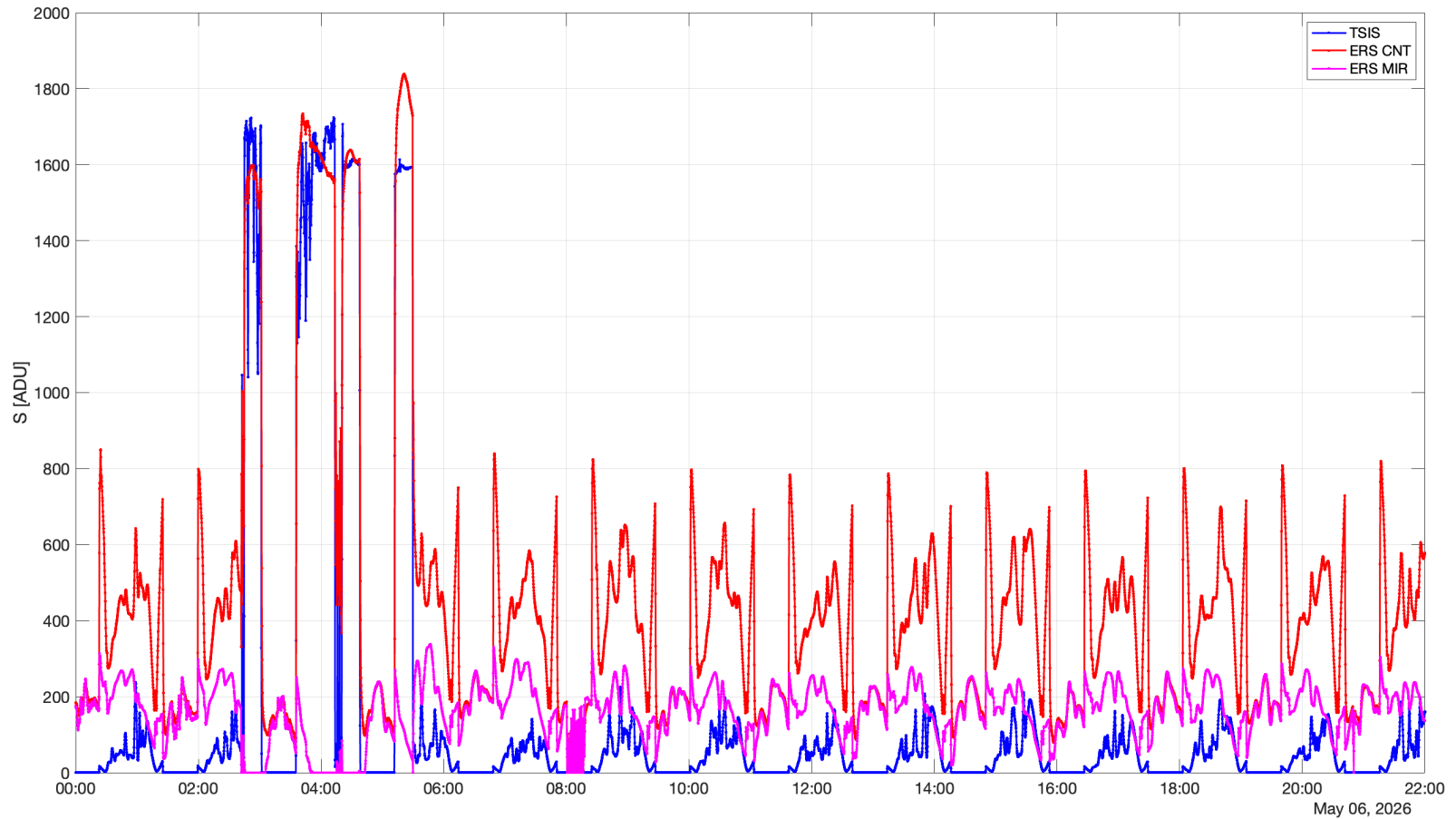

Image prise au-dessus de l'Allemagne, dans le Land du Bade-Wurtemberg, précisément à l'est de la ville de Heilbronn et au sud-ouest d'Öhringen, à environ 594 km d'altitude. Coordonnées au sol : 49,009°N, 9,852°E. N°05241. 16 octobre 2025.

Uvsq-Sat NG a satellite for observing Earth

□ Data – ERB



Uvsq-Sat NG a satellite for observing Earth

□ Data – ERB

Work in Progress



Uvsg-Sat NG a satellite for observing Earth

□ Data – ERB

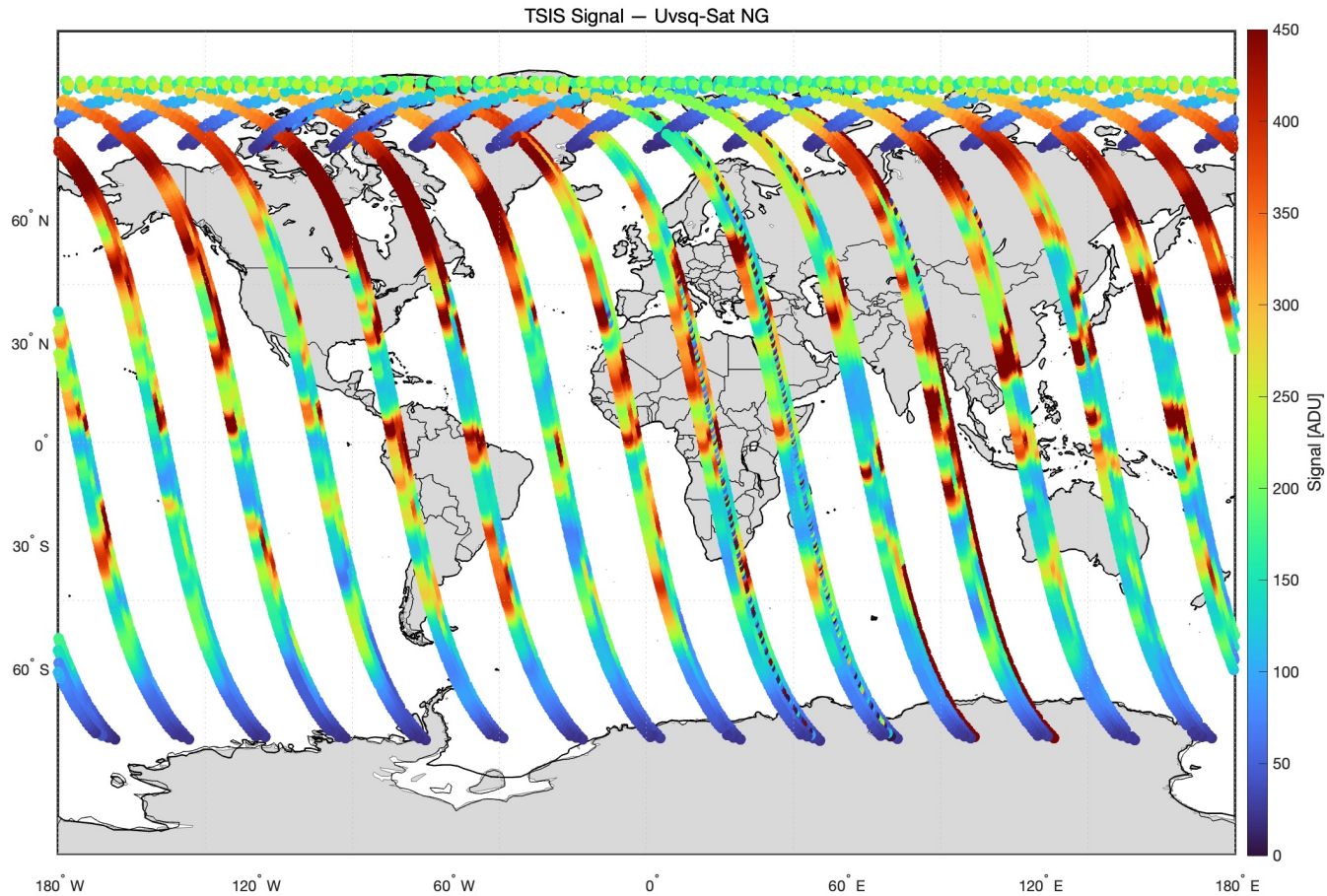

Uvsg-Sat NG a satellite for observing Earth

□ Data – ERB

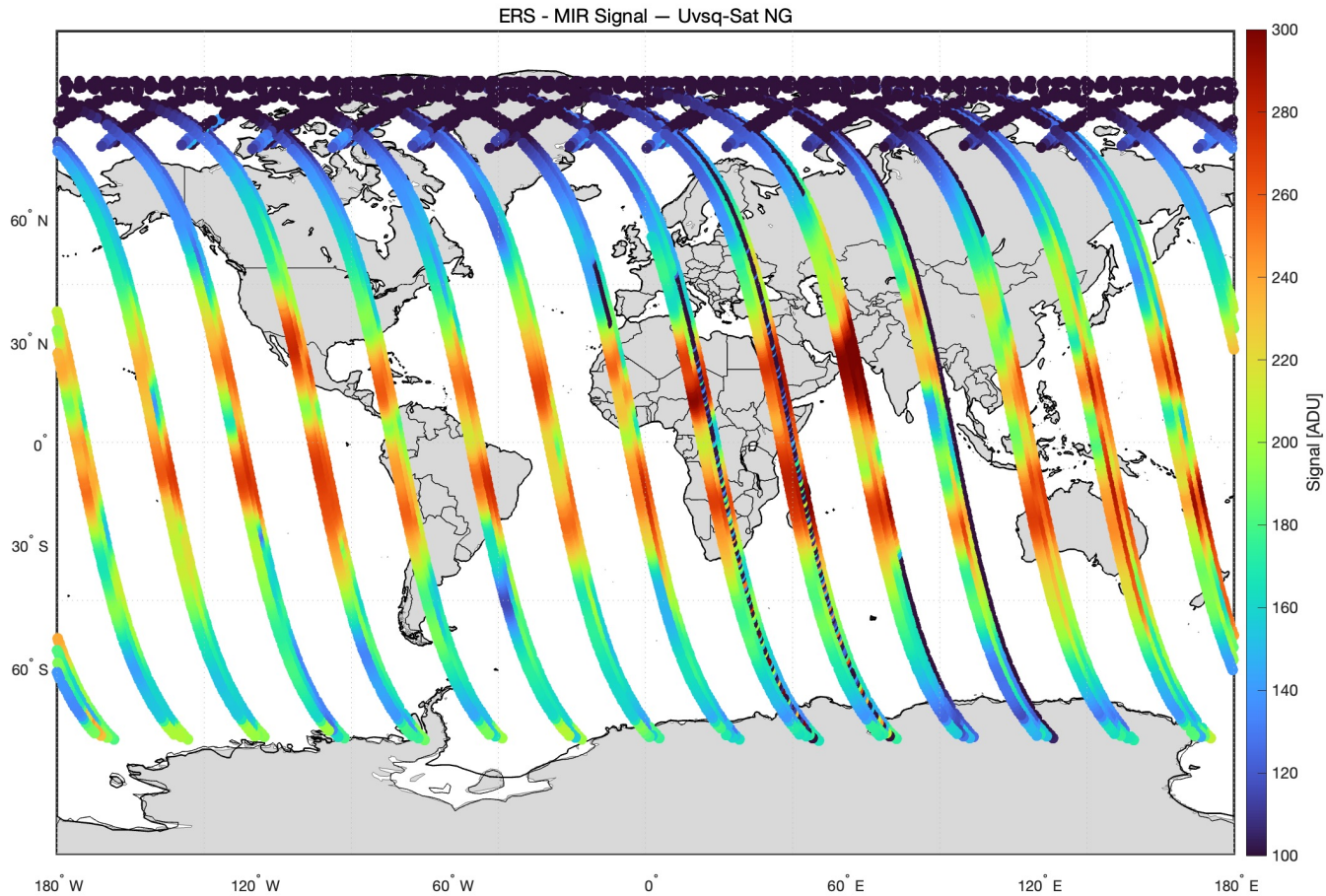

Uvsg-Sat NG a satellite for observing Earth

□ Data → Hyperspectral & GHG

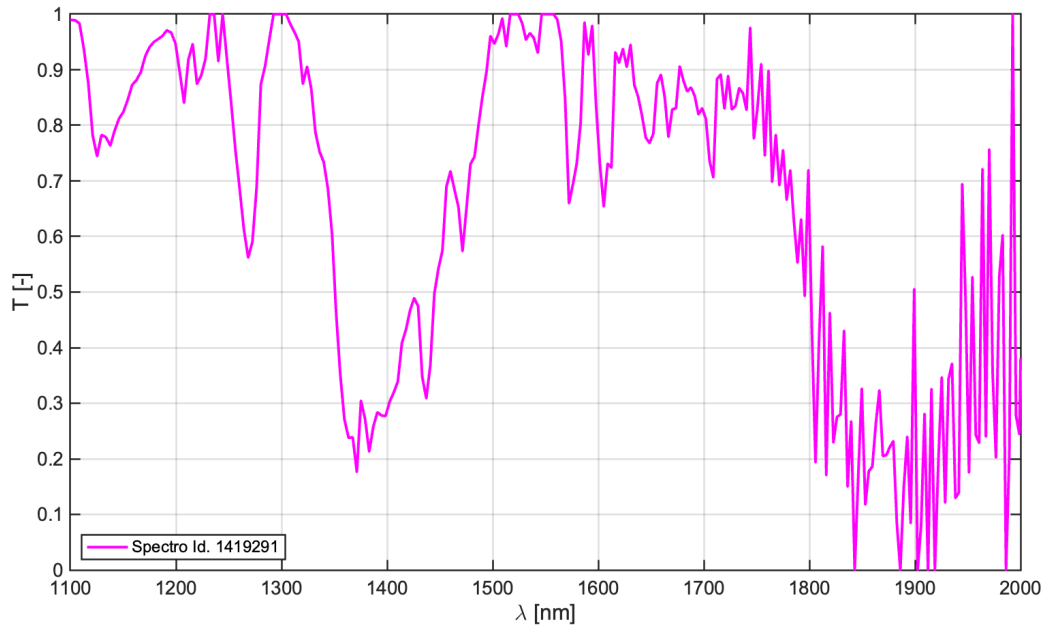

Work in Progress

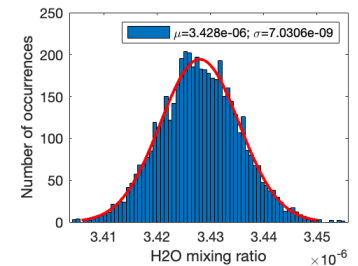
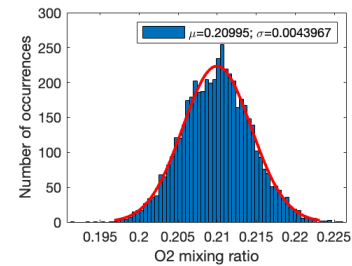
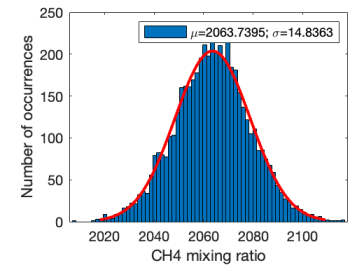
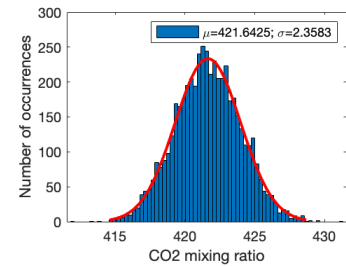

Uvsq-Sat NG a satellite for observing Earth

□ Data → **GHG**

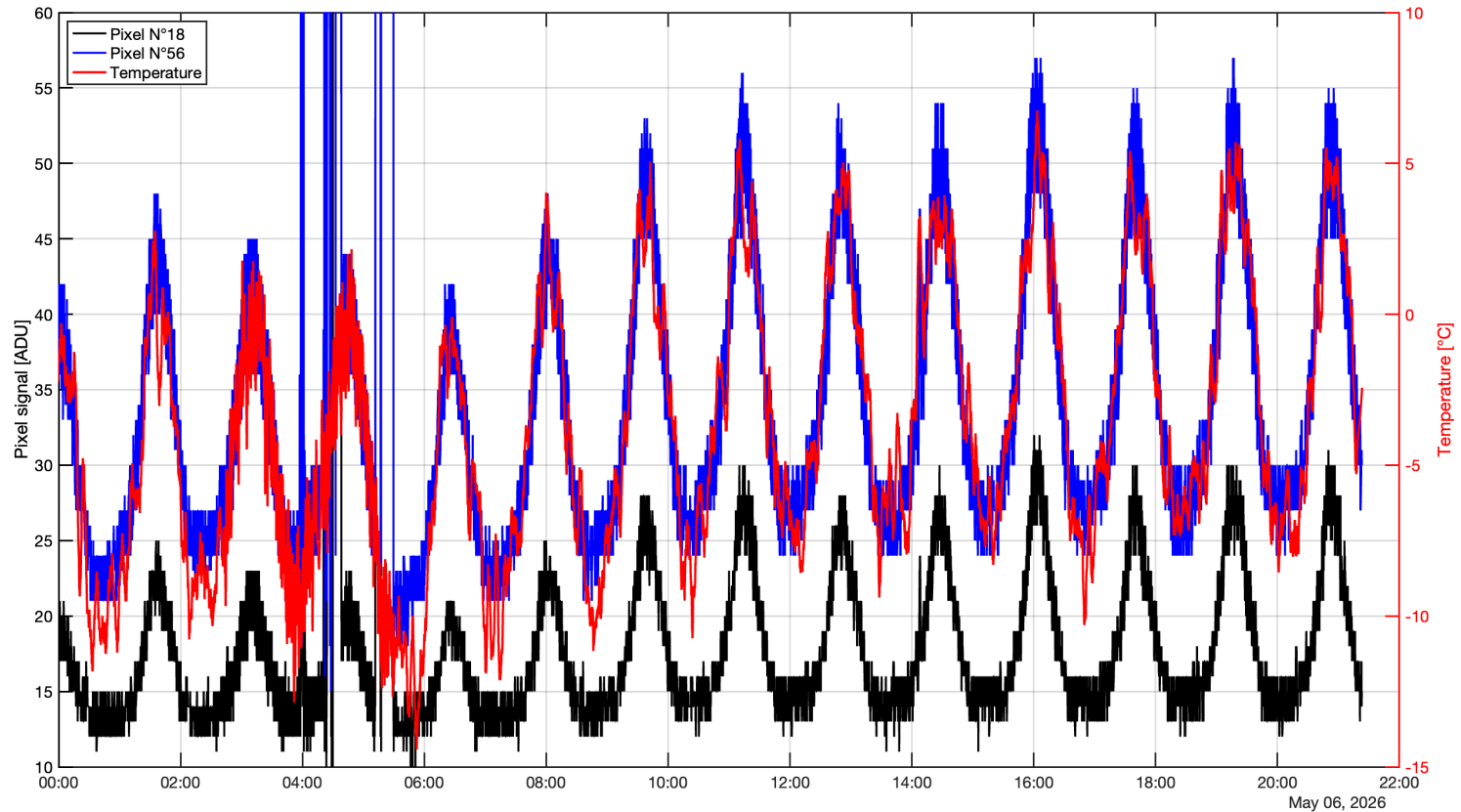

Uvsg-Sat NG a satellite for observing Earth

□ Data → GHG

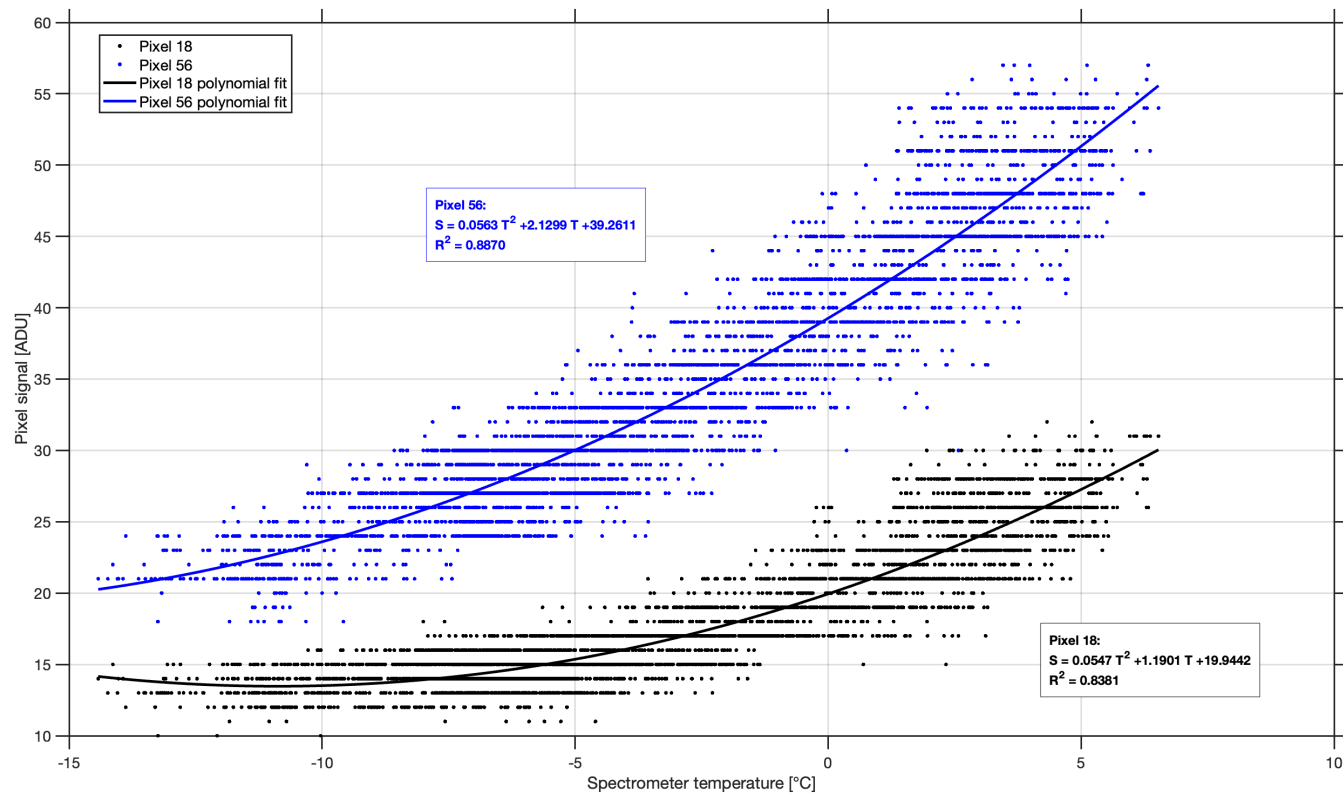

Uvsq-Sat NG a satellite for observing Earth

□ Data → GHG

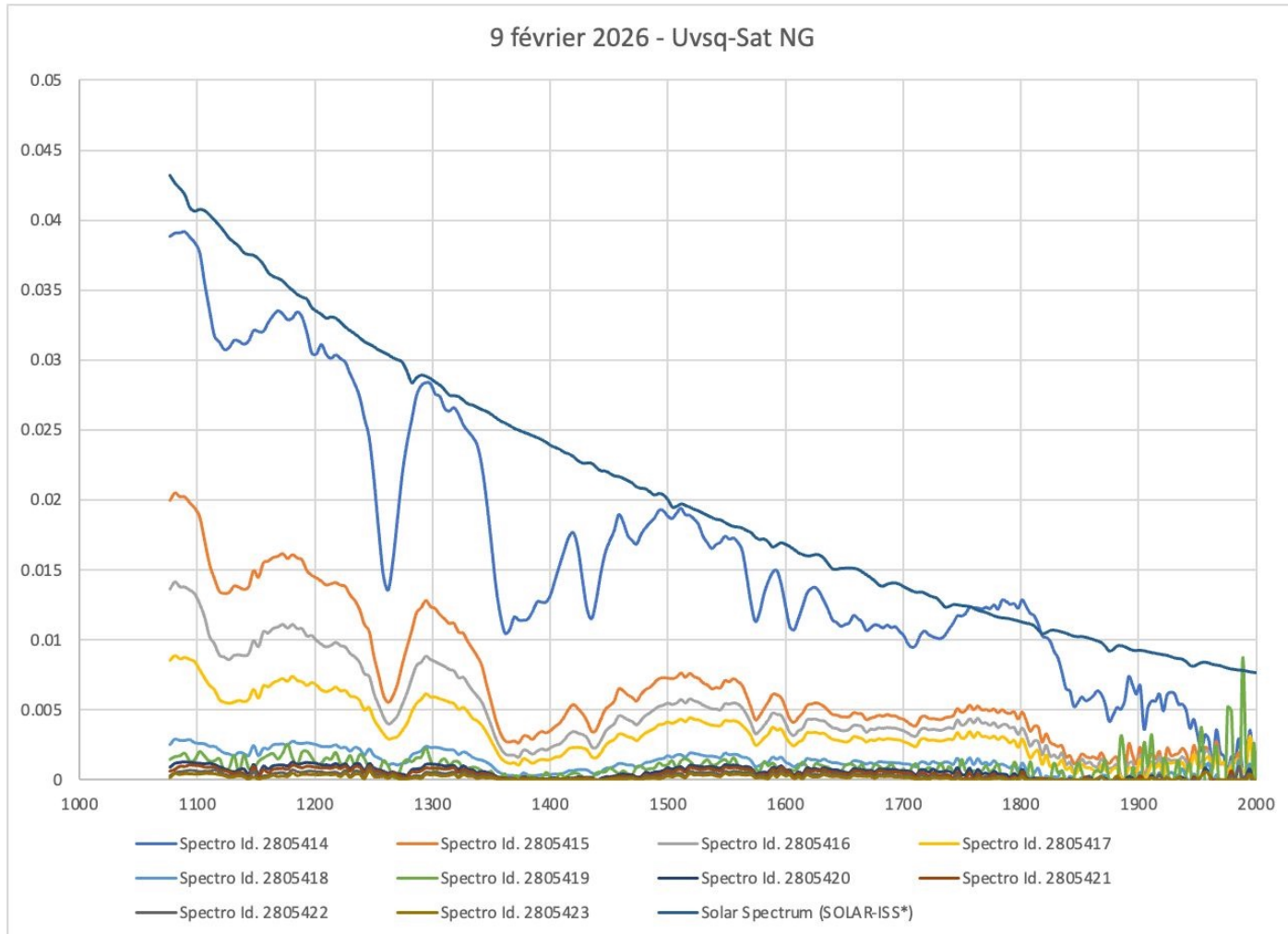

Uvsvq-Sat NG a satellite for observing Earth

□ Data → GHG vs. ERB vs. simulation

CO₂ – 01/10/2025 00H00

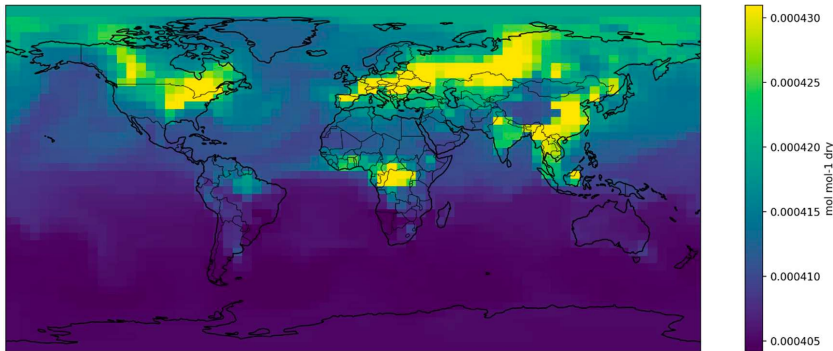

CH₄ – 01/10/2025 00H00

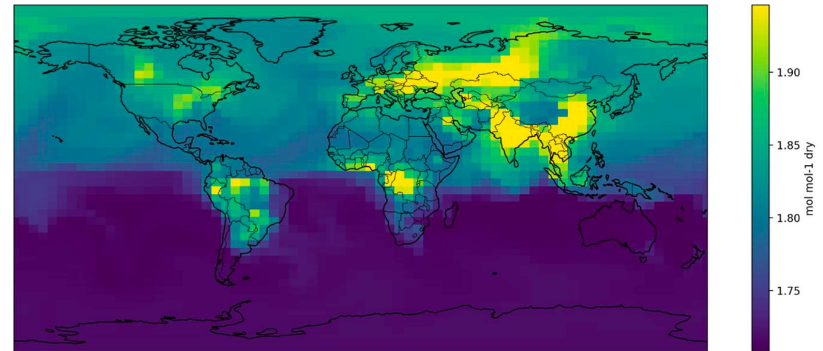

CO₂ – 01/10/2025 12H00

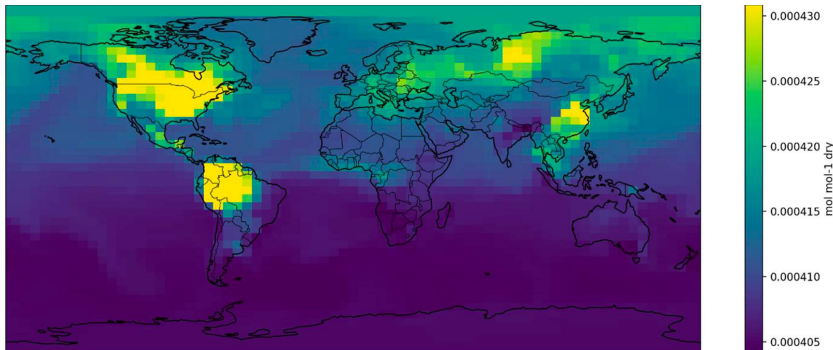

CH₄ – 01/10/2025 12H00

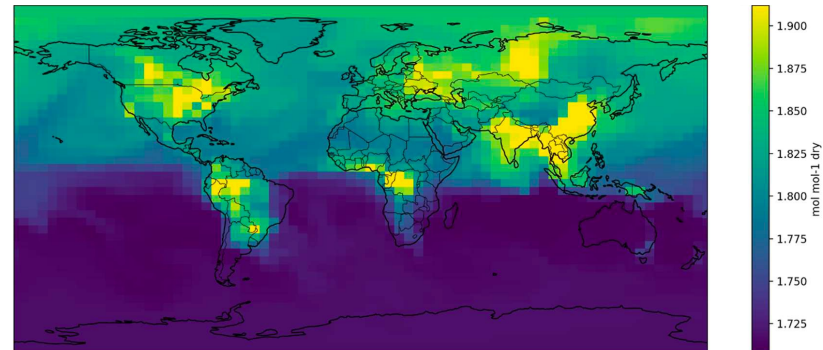

ERB - Anomaly

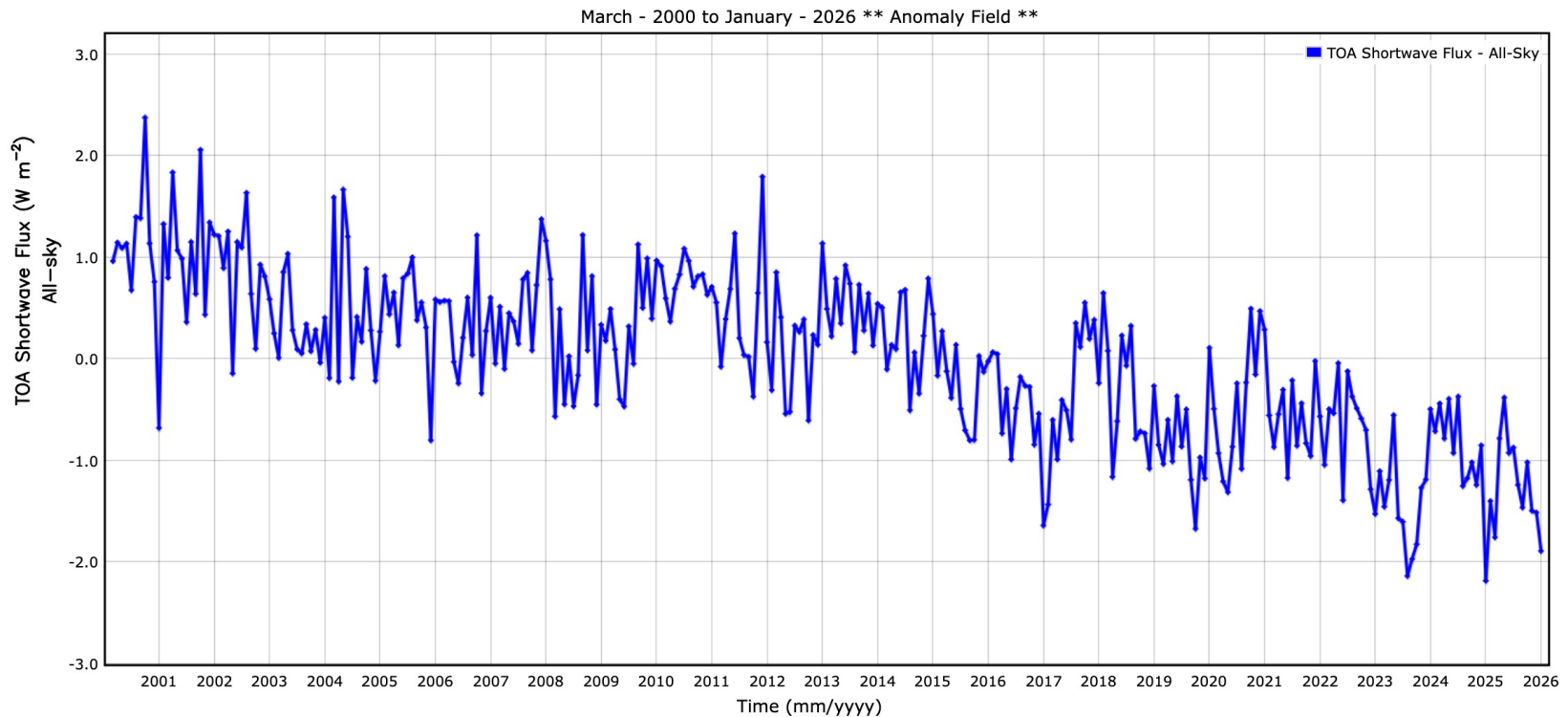

The observed downward trend in OSR since 2000 suggests a decrease in planetary albedo, mainly associated with changes in cloud properties and distribution. These changes are likely influenced by global warming and modifications in large-scale atmospheric circulation patterns.

2023 – A reduction in planetary albedo, mainly driven by cloud changes (especially fewer reflective low clouds during El Niño), with smaller contributions from ice loss and aerosols.

ERB - Anomaly

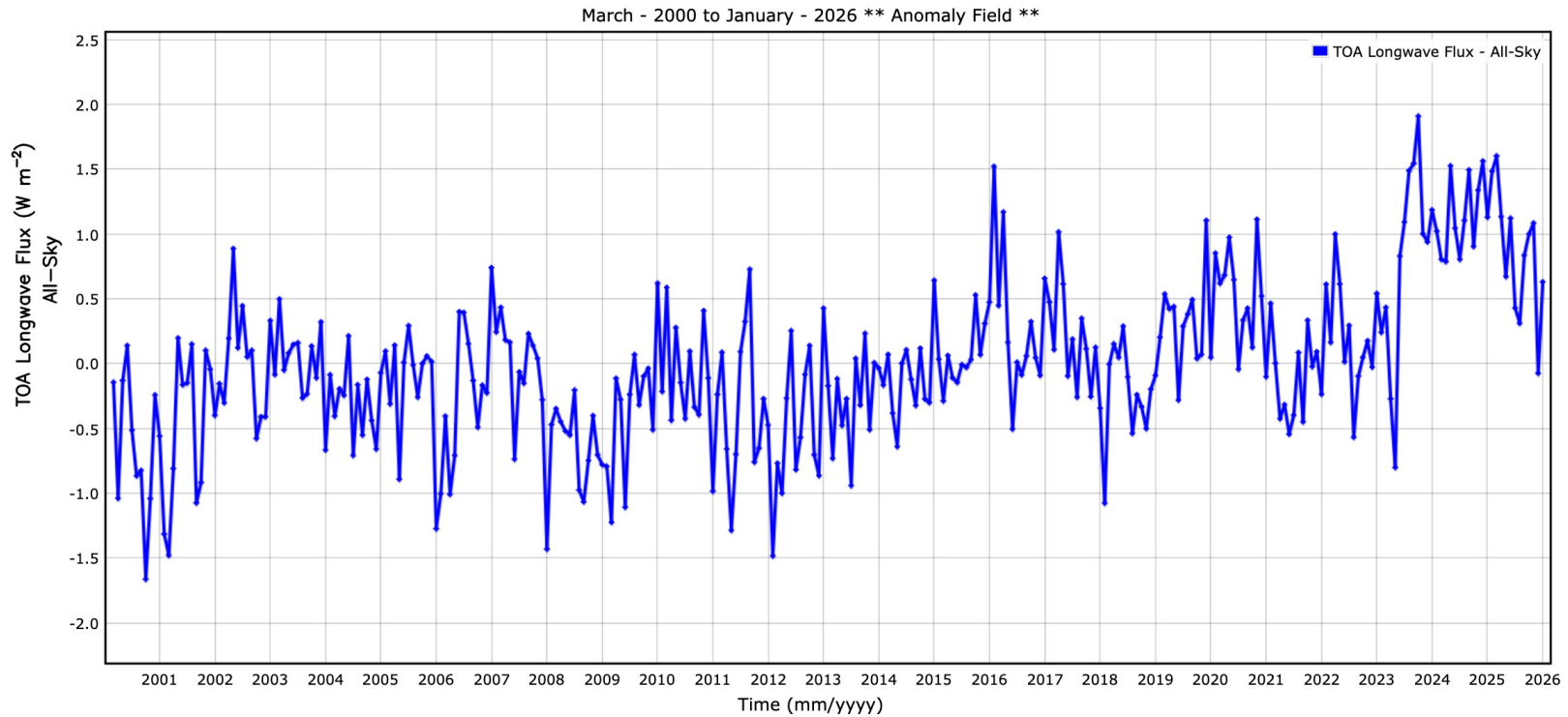

The OLR trend since 2000 reflects stronger infrared emission from a warming climate system, modulated by cloud and circulation variability.

2023 – Record global warming + strong El Niño–driven atmospheric changes (especially clouds and circulation), causing enhanced thermal emission to space.

ERB - Anomaly

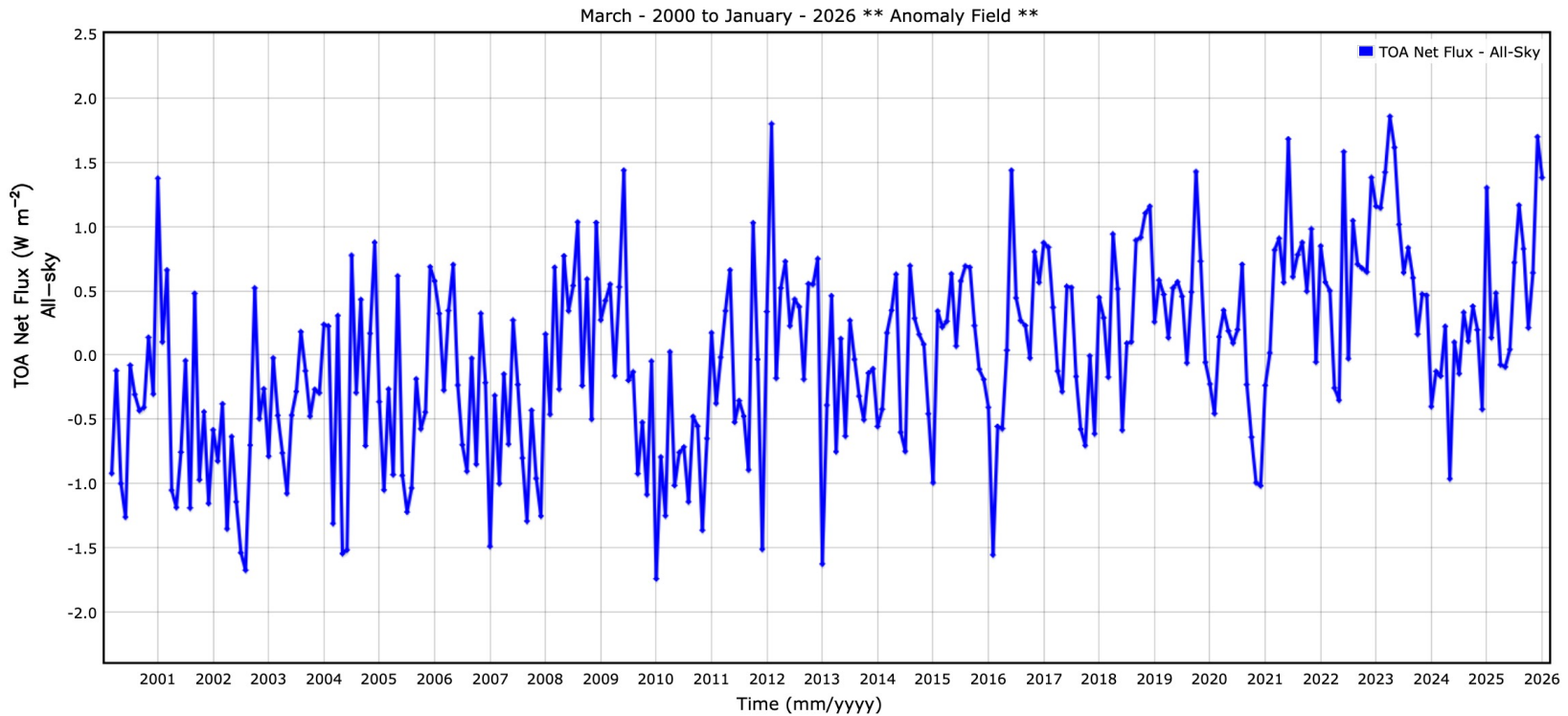

OSR decreasing → albedo ↓ → more absorption

OLR increasing → warming response

But OLR increase < absorbed solar increase

Therefore: **Net radiative flux is positive and growing** → The Earth is warming.

Conclusions

Uvsg-Sat satellites demonstrate the relevance of small satellites for monitoring the Earth Energy Imbalance. Simultaneous Earth and Sun observations create major constraints.

Small satellites mainly provide **relative radiative measurements**, since achieving climate-grade **absolute calibration** remains **extremely challenging on compact platforms**.

Despite absolute accuracies of a few W m^{-2} — above the $<0.5 \text{ W m}^{-2}$ target required for climate-grade ERB observations — these missions successfully capture relative variations and major radiative events.

The comparison with CERES shows encouraging consistency from 2021–2024 with similar temporal evolution, including the 2023 El Niño-related EEI peak.

Wide Field-Of-View observations complement traditional narrow field instruments by:

- Increasing angular coverage
- Improving revisit frequency
- Enhancing resilience through constellation architectures

Future improvements will rely on:

- Better calibration strategies
- Onboard degradation monitoring and cross-calibration between satellites



ACADÉMIE SPATIALE D'ÎLE-DE-FRANCE

Ensemble pour un nouvel espace durable
pour tous et toutes

Compétences et Métiers d'Avenir (CMA) France 2030

<https://academiespatiale.fr>

université
PARIS-SACLAY

SORBONNE
UNIVERSITÉ

Université
Paris Cité

PSL
UNIVERSITÉ PARIS

ONERA
THE FRENCH AEROSPACE LAB

UPEC
UNIVERSITÉ
PARIS-CLERMONT
VAL DE MARNE

POLYTECHNIQUE
DE PARIS

UVSQ
UNIVERSITÉ PARIS-SACLAY

CERES Science Meeting – NASA
May 13, 2026

Mustapha MEFTAH
Alain SARKISSIAN